

PACSystems™ RSTi-EP

PROFINET® SCANNER

(EPXPNS001, EPXPNS001LITE)

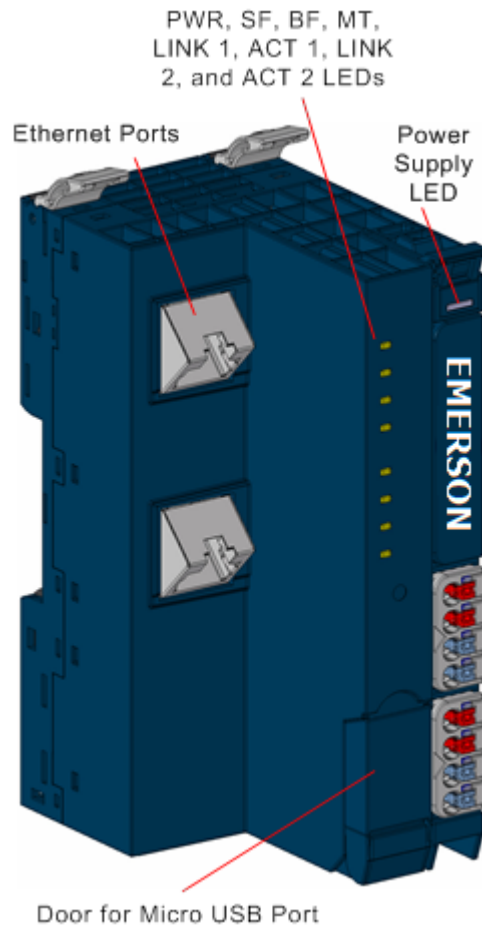

Warnings and Caution Notes as Used in this Publication

WARNING

Warning notices are used in this publication to emphasize that hazardous voltages, currents, temperatures, or other conditions that could cause personal injury exist in this equipment or may be associated with its use.

In situations where inattention could cause either personal injury or damage to equipment, a Warning notice is used.

CAUTION

Caution notices are used where equipment might be damaged if care is not taken.

Note: Notes merely call attention to information that is especially significant for understanding and operating the equipment.

These instructions do not purport to cover all details or variations in equipment, nor to provide for every possible contingency that may arise during installation, operation, and maintenance. The information is supplied for informational purposes only, and Emerson makes no warranty as to the accuracy of the information included herein. Changes, modifications, and/or improvements to equipment and specifications are made periodically, and these changes may or may not be reflected herein. It is understood that Emerson may make changes, modifications, or improvements to the equipment referenced herein or to the document itself at any time. This document is intended for trained personnel familiar with the Emerson products referenced herein.

Emerson may have patents or pending patent applications covering subject matter in this document. The furnishing of this document does not provide any license whatsoever to any of these patents.

Emerson provides the following documents and the information included therein as-is and without warranty of any kind, expressed or implied, including but not limited to any implied statutory warranty of merchantability or fitness for a particular purpose.

Product Description

The EPXPNS001 PROFINET Scanner is a PROFINET I/O device certified by the PROFINET user organization. The network adapter is the head module for the RSTi-EP system bus, to which up to 64 active RSTi-EP modules can be connected. The PROFINET network adapter has two Ethernet ports and an integrated switch.

The PROFINET Scanner can be accessed with a system-independent web server application via the USB service interface or the Ethernet. Thus, all information, such as diagnostics, status values, and parameters, can be read, and all connected modules can be simulated or forced.

The station's main power supply is integrated with the PROFINET Scanner. Power is supplied via two 4-pole connectors, separated into the input and output current paths.

The EPXPNS001LITE PROFINET Scanner is a certified PROFINET I/O device and serves as the head module for the RSTi-EP system bus, supporting up to 16 active RSTi-EP modules. It features two Ethernet ports with an integrated switch for flexible networking.

Through the RJ-45 Ethernet interface, the scanner can be accessed via a system-independent web server application. This interface allows users to view diagnostics, status values, and parameters, as well as simulate or force all connected modules.

Note: EPXPNS001LITE does not support EP-12F4 (Time stamp) and EP-5714 (HART) IO modules.

Caution: the RSTi-EP station is usually installed on a horizontally positioned DIN rail. Installation on vertically positioned DIN rails is also possible. However, the heat dissipation is reduced such that the derating values change (refer to the section, Thermal Derating).

Modules should be allowed to de-energize for a minimum of 10 seconds after powering down, before starting any maintenance activity. The PROFINET Scanner cannot be hot-swapped.

Refer to the RSTi-EP Slice I/O User Manual (GFK-2958) for additional information.

Refer to the RSTi-EP Power Supply Reference Guide, a software utility available on PAC Machine Edition (PME) V9.00, for detailed power-feed requirements.

Module Features

- EPXPNS001 supports up to 64 active RSTi-EP modules
- EPXPNS001LITE supports up to 16 active RSTi-EP modules
- *Spring-style* technology for ease of wiring
- DIN rail mounted
- Double-click installation for a positive indication of correct installation
- Built-in Web Server for diagnostic information and firmware update through Ethernet and micro-USB port

Webserver	Ethernet RJ-45	Micro USB
EPXPNS001	✓	✓
EPXPNS001LITE	✓	-

- Supports Media Redundancy Protocol (MRP) Client mode operation
- Support for daisy-chain/line, star, or ring (MRP) technologies
- Two switched Ethernet ports; 8-conductor RJ-45 shielded twisted pair 10/100 Mbps copper interfaces
- Fast start-up < 500 ms with a maximum of 10 modules.

Ordering Information

Module	Description
EPXPNS001	RSTi-EP Slice I/O PROFINET IRT Network Adapter, supports 64 active IO modules.
EPXPNS001LITE	RSTi-EP Slice I/O PROFINET RT Network Adapter supports 16 active IO modules.

Specifications EPXPNS001

Specifications	EPXPNS001	
System data		
Connection	2 x RJ-45	
Fieldbus protocol	PROFINET Version 2.3 Class C I/O Device (IRT, RT)	
Process image	Input data width	max. 512 bytes
	Output data width	max. 512 bytes
	Parameter data	max. 4362 bytes
	Diagnostic data	max. 1408 bytes
Number of modules	max. 64 active	
Configuration interface	Micro USB 2.0	
Transfer rate	Fieldbus	Max. 100 Mbps
	RSTi-EP system bus	Max. 48 Mbps
Data format	Default: Motorola	Configurable: Intel
PROFINET I/O Update Rate	Configurable selections: 1ms, 2ms, 4ms, 8ms, 16ms, 32ms, 64ms, 128ms, 256ms, and 512ms	
Supports MRP	Yes * [Minimum I/O Update Rate for bump-less operation in an MRP ring topology is 32ms and slower for EPXPNS001]	
Supply		
Supply voltage for the system and inputs	20.4V – 28.8V	
Supply voltage for outputs	20.4V – 28.8V	
Max. feed-in current for input modules	10 A	
Max. feed-in current for output modules	10 A	
Current consumption from the system current path I_{sys}	116 mA	
Connection data		
Type of connection	<i>Spring style</i>	
Conductor cross-section	Single-wired, fine-wired	0.14 – 1.5 mm ² (AWG 26 – 16)

Specifications	EPXPNS001
General Data	
Operating temperature	-20°C to +60°C (-4 °F to +140 °F)
Storage temperature	-40°C to +85°C (-40 °F to +185 °F)
Air humidity (operation/transport)	5% to 95%, noncondensing as per DIN EN 61131-2
Width	52 mm (2.05 in)
Depth	76 mm (2.99 in)
Height	120 mm (4.72 in)
Weight	220 g (7.76 oz)
Configuration	V2.3 GSDML file is available on the support website (http://pacsystems.co/support) for download and import into PAC Machine Edition. The GSDML supporting a firmware release is part of the firmware upgrade kit available on the Support website.

Specifications EPXPNS001LITE

Specification	Description	
System Data		
Connection	2 x RJ-45	
Fieldbus protocol	PROFINET I/O (RT)	
PROFINET System Redundancy Support	MRP	
Application Relations Supported	1 Simplex AR	
Process image	Input data width	max. 512 bytes
	Output data width	max. 512 bytes
	Parameter data	max. 4362 bytes
	Diagnostic data	max. 1408 bytes
Number of modules	max. 16 active	
Configuration interface	Via RJ45	
Transfer rate	Fieldbus	Max. 100 Mbps
	RTSi-EP system bus	Max. 48 Mbps
Fast start-up	> 1 s	
Data format	Default: Motorola Configurable: Intel	
Status Bits	16 Input Status Bits Refer --Network Adaptor Input Status Data	
PROFINET I/O Update Rate	Configurable selections: 1ms, 2ms, 4ms, 8ms, 16ms, 32ms, 64ms, 128ms, 256ms and 512ms	
Supports MRP	Yes * [Minimum I/O Update Rate for bump less operation in an MRP ring topology is 32ms and slower for EPXPNS001]	
Supply		

Specification	Description	
Supply voltage for the system and inputs	20.4 V – 28.8 V	
Supply voltage for outputs	20.4 V – 28.8 V	
Max. feed-in current for input modules	10 A	
Max. feed-in current for output modules	10 A	
Current consumption from the system current path I_{SYS}	80 mA	
Connection Data		
Type of connection	"PUSH IN"	
Conductor cross-section	Single-wired, fine-wired	0.14 – 1.5 mm ² (AWG 26 – 16)
General Data		
Operating temperature	0 °C to +50 °C (32 °F to +122 °F)	
Storage temperature	-40 °C to +85 °C (-40 °F to +185 °F)	
Air humidity (operation/transport)	10% to 95%, noncondensing as per DIN EN 61131-2	
Width	52 mm (2.05 in)	
Depth	76 mm (2.99 in)	
Height	120 mm (4.72 in)	
Weight	242 g (8.54 oz)	
Configuration	The V2.33 GSDML file is available on the support site (http://pacsystems.co/support) for download and import into PAC Machine Edition. The GSDML supporting firmware release is part of the firmware upgrade kit, also available on the Support website.	

LEDs

LED Status Indicators EPXPNS001/EPXPNS001LITE

LED	Indication	LED State/Description
PWR	Power LED	Green: Supply voltage connected
SF	System fault	Red: Configuration error, or error in the PROFINET Scanner, or error in a module, or there is a new diagnostic report. Red flashing: Station in Force mode
BF	Bus fault	Red: No connection to the Fieldbus Red flashing: Configuration error, no connection to the control unit, or error in the parameter set
MT	Maintenance Required	Yellow: Error on the system bus or Fieldbus
LINK 1	Connection	Green: Connection established between port 1 of the PROFINET Scanner and another field device
ACT 1	Active	Yellow flashing: Data being exchanged on port 1
LINK 2	Connection	Green: Connection established between port 2 of the PROFINET Scanner and another field device
ACT 2	Active	Yellow flashing: Data being exchanged on port 2

LED Indicators EPXPNS001



LED	EPXPNS001
Power Supply	Green: Supply voltage > 18 V DC Red: At least one current path < 18 V

3.1	Green: Input current path supply voltage > 18 V DC
3.2	Red: Input current path supply voltage < 18 V DC
3.3	
3.4	Red: Internal fuse defective
4.1	Green: Output current path supply voltage > 18 V DC
4.2	Red: Output current path supply voltage < 18 V DC
4.3	
4.4	Red: Internal fuse defective



LED	EPXPNS001LITE
Power Supply	Green: Supply voltage > 18 V DC Red: At least one current path < 18 V

- 4.1 **Green:** Output current path supply voltage > 18 V DC
- 4.2 **Red:** Output current path supply voltage < 18 V DC
- 4.3
- 4.4

Field Wiring

The connection frame has one connector, and two 24 V DC wires can be connected to each connector, along with two ground connections. Those four connectors are used as shown in the following figure. The Spring style technology allows either finely stranded or solid wire with crimped wire-end ferrules or ultrasonically welded wires, each with a maximum cross-section of 1.5 mm² (16 gauge), to be inserted easily through the opening in the clamping terminal without having to use tools. To insert fine stranded wires without wire-end ferrules, the pusher must be pressed in with a screwdriver and released to latch the wire.

Figure 1: Connector Block

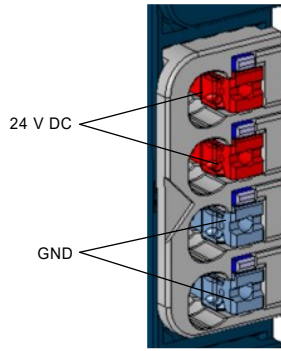

Connector Specifications

- Conductor cross-section 0.14 to 1.5 mm² (26 – 16 gauge)
- Maximum ampacity: 10 A
- 4-pole

The modules do not have a fused sensor/activator power supply. All cables to the connected sensors/actuators must be fused corresponding to their conductor cross-sections (as per Standard DIN EN 60204-1, section 12).

Refer to the RSTi-EP Slice I/O User Manual (GFK-2958) for additional information.

For technical assistance, go to <http://pacsystems.co/support>

Connection Diagrams

Figure 2: EPXPNS001

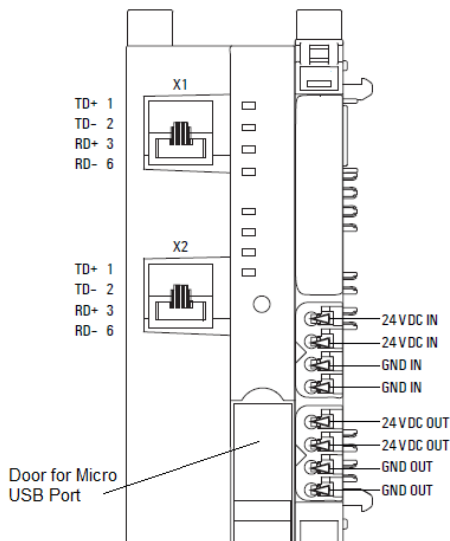
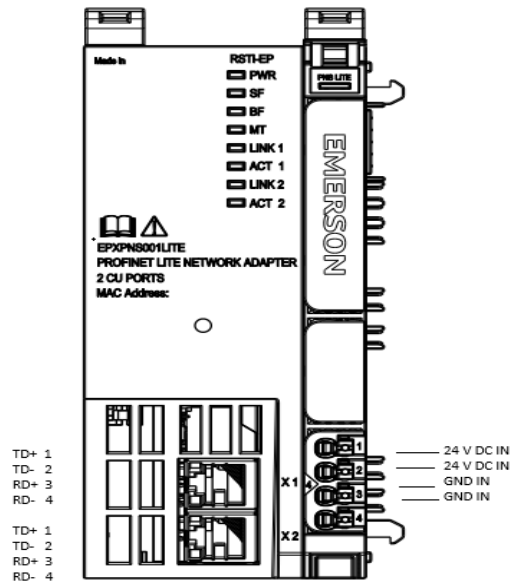

Figure 3: EPXPSN001LITE



Connection Block Diagrams

Figure 4: EPXPNS001

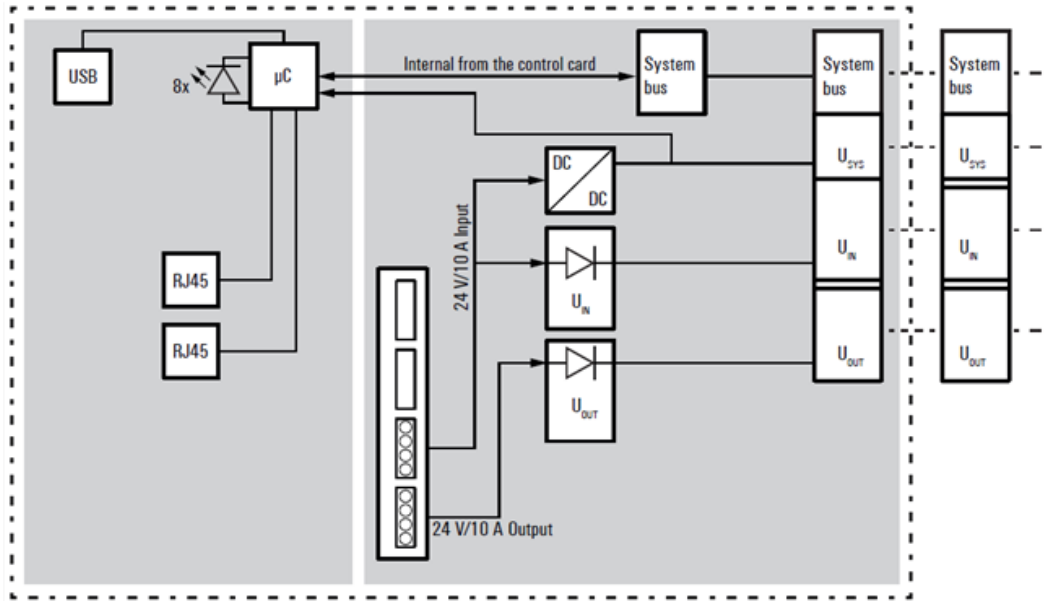
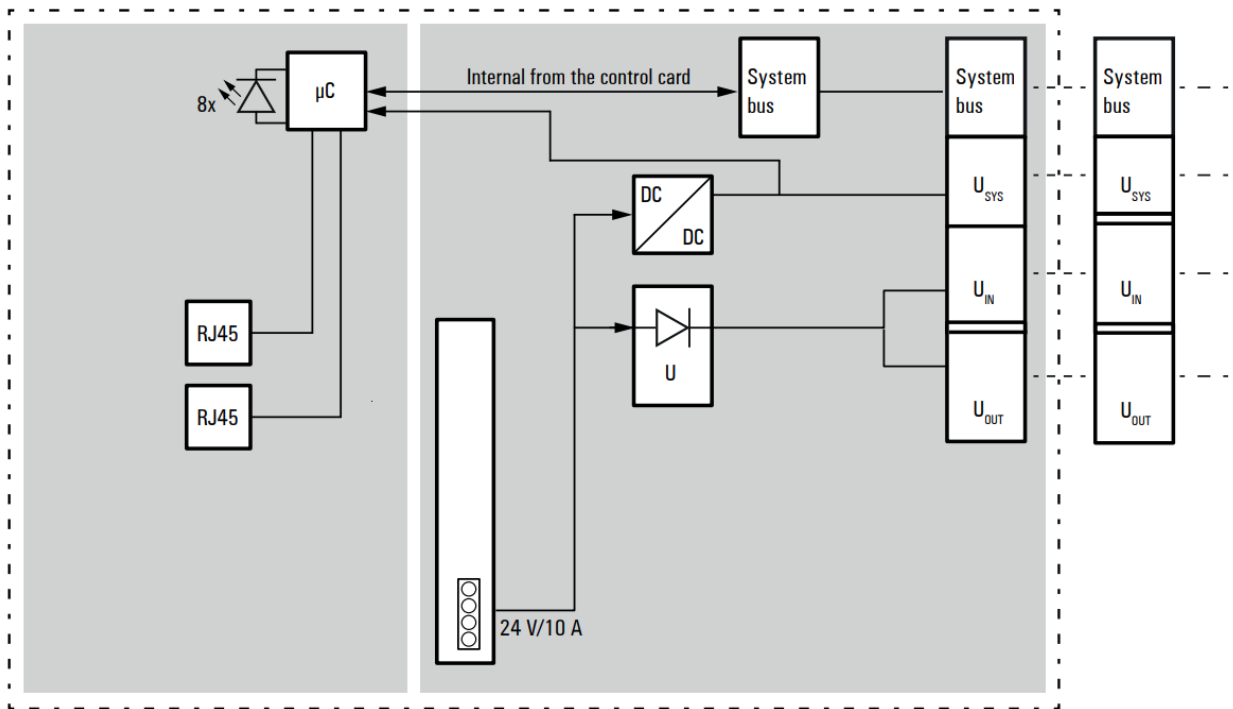

Figure 5: EPXPNS001LITE



Installation in Hazardous Areas

⚠ WARNING

- EQUIPMENT LABELED WITH REFERENCE TO CLASS I, GROUPS A, B, C & D, DIV. 2 HAZARDOUS AREAS IS SUITABLE FOR USE IN CLASS I, DIVISION 2, GROUPS A, B, C, D OR NON-HAZARDOUS AREAS ONLY
- EXPLOSION HAZARD – SUBSTITUTION OF COMPONENTS MAY IMPAIR SUITABILITY FOR CLASS I, DIVISION 2;
- EXPLOSION HAZARD – WHEN IN HAZARDOUS AREAS, TURN OFF POWER BEFORE REPLACING OR WIRING MODULES; AND
- EXPLOSION HAZARD – DO NOT CONNECT OR DISCONNECT EQUIPMENT UNLESS POWER HAS BEEN SWITCHED OFF OR THE AREA IS KNOWN TO BE NONHAZARDOUS.

ATEX Marking

⊕ II 3 G Ex Na IIC T4 Gc

Ta: -20°C to +60°C (-4° F to +140 °F)

** Not applicable for EPXPNS001LITE.

Thermal Derating

The power supply is restricted according to the temperature. The following values apply for the horizontal and vertical positioning of the RSTi-EP station:

Temperature-dependent Values for the Power Supply

Power Supply	Network Adaptor	Horizontal	Vertical
Network adapter power supply	EPXPNS001	60°C (140 °F) : 2 x 8 A 55°C (131 °F) : 2 x 10 A	55°C (131 °F) : 2 x 6 A 50°C (122 °F) : 2 x 8 A
	EPXPNS001LITE	50°C (122 °F) : 10 A	50°C (122 °F) : 8 A 45°C (113 °F) : 10 A
Power-feed module power supply	EPXPNS001	60°C (140 °F) : 1 x 10 A	55°C (131 °F) : 1 x 8 A
	EPXPNS001LITE	50°C (122 °F) : 10 A	45°C (113 °F) : 8 A

Refer to the RSTi-EP Slice I/O Module User Manual (GFK-2958) for additional information.

Supported Modules and Power Supplies

The following modules can be used with this release of the RSTi-EP PROFINET Network Adapter.

Catalog Number	Module Description
Digital Input Modules	
EP-1214	Digital Input, 4 Points, Positive Logic 24VDC, 2,3, or 4 Wire
EP-1218	Digital Input, 8 Points, Positive Logic, 24VDC 2 Wire
EP-12A8	Digital Input, 8 Points, Positive Logic, 2-Wire, Isolated
EP-1318	Digital Input, 8 Points, Positive Logic, 24VDC 3 Wire
EP-125F	Digital Input, 16 Points, Positive Logic, 24VDC, 1 Wire
EP-153F	Digital Input, 16 Points, Negative Logic, 24VDC, 1 Wire
EP-12F4	Digital Input, 4 Points, Positive Logic 24VDC, 2,3, or 4 Wire, Timestamp
EP-1804	Digital Input, 4 Points 110/230 VAC (65 – 277 VAC), 2 Wire, Isolated
Digital Output Modules	
EP-2214	Digital Output, 4 Points, Positive Logic 24VDC, 0.5A, 2,3, or 4 Wire
EP-22A4	Digital Output, 4 Points, Positive Logic, 24VDC, 4A DC or 2A AC, 2 Wire, Isolated
EP-2614	Digital Output, 4 Points, Positive Logic 24VDC, 2.0A, 2,3, or 4 Wire
EP-2634	Digital Output, 4 Points, Positive/Negative Logic 24VDC, 2.0A, 2,3, or 4 Wire
EP-2218	Digital Output, 8 Points, Positive Logic, 24VDC, 0.5A, 2 Wire
EP-225F	Digital Output, 16 Points, Positive Logic, 24VDC, 0.5A, 1 Wire
EP-291F	Digital Output, 16 Points, Negative Logic, 24VDC, 0.5A, 1 Wire
Digital Relay Output Modules	
EP-2714	Digital Relay Output, 4 Points, Positive Logic, 24 - 220 VDC/VAC, 6A, 2 Wire
EP-2814	Solid-state Relay Output Module
Analog Input Modules	
EP-3164	Analog Input, 4 Channels Voltage/Current 16 Bits 2, 3, or 4 Wire
EP-3264	Analog Input, 4 Channels Voltage/Current 16 Bits with Diagnostics 2, 3, or 4 Wire
EP-32A4	Analog Input, 4 channels, Isolated Voltage/Current, 16 Bits with Diagnostics, 2 Wire
EP-3124	Analog Input, 4 Channels Voltage/Current 12 Bits 2, 3, or 4 Wire
EP-3368	Analog Input, 8 Channels Current 16 Bits 2, 3, or 4 Wire
EP-3468	Analog Input, 8 Channels Current 16 Bits 2, 3, or 4 Wire, Channel Diagnostic
EP-3704	Analog Input, 4 Channels RTD 16 Bits with Diagnostics 2, 3, or 4 Wire
EP-3804	Analog Input, 4 Channels TC 16 Bits with Diagnostics 2, 3, or 4 Wire
EP-1813	Power Measurement Module, 8 Channels
EP-3914	Analog Input (Potentiometer), 4 Channels, 16 bits with Diagnostics, 3-wire or 3-wire connection +FE

Catalog Number	Module Description
Analog Output Modules	
EP-4164	Analog Output, 4 Channels Voltage/Current 16 Bits 2, 3, or 4 Wire
EP-4264	Analog Output, 4 Channels Voltage/Current 16 Bits with Diagnostics 2, 3, or 4 Wire
EP-42A2	Analog Output, Isolated, 2 Channels Voltage/Currents 16 Bits Diagnostics 2-Wires
Speciality Modules	
EP-5111	1 Channel High Speed Counter, AB 100 kHz 1 DO 24VDC, 0.5A
EP-5112	2 Channel High Speed Counter, AB 100 kHz
EP-5212	2 Channel Frequency Measurement, 100 kHz
EP-5121	1 Channel High Speed Counter, AB 500 kHz
EP-5261	1 Channel Serial Communications, 232, 422, 485
EP-5311	1 Channel SSI Encoder, BCD or Gray-Code Format, 5/24 VDC
EP-5422	2 Channels PWM Output, Positive Logic, 24VDC, 2.0 A
EP-5442	2 Channels PWM Output, Positive Logic, 24VDC, 0.5 A
EP-5324	IO-Link Communication Module, 4 Channels
EP-5714	4 channels, Analog HART Input, Current 16 Bits with Diagnostics 2, 3, or 4 Wire
EP-5612	2 channels, Strain gauge, 24 Bits with diagnostics, 4 or 6 wire
EP-5501	1 Channel Stepper Motor, 2-phase.
Power Feed Modules for Input Current Path	
EP-7631	Power Module, 1 Channel 24VDC Input Flow 10A
Power Feed Modules for Output Current Path	
EP-7641	Power Module, 1 Channel 24VDC Output Flow 10A
Safe Feed-input Modules	
EP-1901	1 Safe Feed-Input, 24 VDC
EP-1902	2 Safe Feed-Inputs, 24 VDC, Programmable Delay
EP-1922	2 Safe Feed-Inputs, 24 VDC
Potential Distribution Modules	
EP-711F	Power Module, 16 Channels 24VDC Potential Distribution +24 VDC from Input Current Path
EP-751F	Power Module, 16 Channels, 24VDC Potential Distribution +24 VDC from Output Current Path
EP-700F	Power Module, 16 Channels, 24VDC Potential Distribution Functional Earth
EP-710F	Power Module, 16 Channels 24VDC Potential Distribution +0VDC from Input Current Path
EP-750F	Power Module, 16 Channels 24VDC Potential Distribution +0VDC from Output Current Path
Hot Swap Modules	
EP-7990	Bump-less Output Hot Swap Module
Note: EPXPNS001LITE doesn't support EP-12F4 (Time stamp) and EP-5714 (HART) IO modules.	

Release History

Catalog Number	Hardware Version	Firmware Version	Date	Comments
EPXPNS001LITE-ABAA	01.00.00	01.00.00	Apr 2026	Updated product label to include CCC marking.
EPXPNS001LITE-AAAA	01.00.00	01.00.00	Sep 2025	Initial release of EPXPNS001LITE
EPXPNS001-AFAL	02.00.00	02.06.05	Apr 2025	Updated firmware to support the addition of IO modules.
EPXPNS001-AFAK	02.00.00	02.06.04	Nov 2024	- Updated Product marking to include CCC.
EPXPNS001-AEAK	02.00.00	02.06.04	Feb 2024	- Firmware release 02.06.04 - Support for EP-7990 is added to enable bump-less hot-swap operation
EPXPNS001-ADAJ	02.00.00	02.06.02	Jun 2022	Firmware release 02.06.02
EPXPNS001-ADAH	02.00.00	02.05.03	Dec 2021	- Release of Firmware modified with increased startup timeout to support IO-link devices having longer startup times
EPXPNS001-ADAH	02.00.00	02.05.01 FSBL: 01.08.00	Nov 2020	- Release of FW file with integrated FSBL image for EPXPNS001. - Error fixes-"Valid module substitution" fault on EPXPNS001 -when the node is downloaded to the controller.
EPXPNS001-ADAG	02.00.00	02.04.02 FSBL: 01.08.00	Mar 2020	EPXPNS001 is released with HW version 02.00.00 & with FW 02.04.02, the same as EPXPNS101.
EPXPNS001-ACAF	01.05.00	02.03.01	Dec 2019	Support for two newly introduced IO modules, EP-1813 (Power Measurement module) and EP-5324 (IO-Link Communication Module), with only an IPI update.
EPXPNS001-ACAF	01.05.00	02.03.01	Dec 2019	Firmware corrected for the display of the appropriate Device Type for EPXPNS001 for "Explore Profinet" and "Profinet DCP" Tools in Machine Edition.

Catalog Number	Hardware Version	Firmware Version	Date	Comments
EPXPNS001-ACAE	01.05.00	02.03.00	Sep 2019	<ul style="list-style-type: none"> - Following Emerson’s acquisition of this product, changes have been made to apply appropriate branding and registration of the product with the required certification agencies. No changes to the material, process, form, fit, or functionality. - Support for new Negative logic Digital Input module(EP-153F) & Digital Output Module (EP-291F) - Updates to webserver <ul style="list-style-type: none"> - Ordering data is removed from General information section of Emerson-branded products. - Brand labeling of Web Application to EMERSON.
EPXPNS001-ABAD	01.05.00	02.02.00	Mar 2018	<p>The product revision is updated to be usable in marine/shipbuilding applications and pass marine certification tests. [DNV-GL & Lloyd’s Register]</p> <p>Enhancements and updates to Web Application :</p> <ul style="list-style-type: none"> - Reset button appears automatically when changes in parameter settings require a restart to take effect - Added display of slot numbers to the list of compatible modules after selecting a firmware file in multi-update view. - Added password policy and weak password check - default username and password will remain the same. - New languages for Web Server available [Korean, French, Spanish, Portuguese, and Italian] - Support for EP-3664 <p>Issue Fixes :</p> <ul style="list-style-type: none"> - Fixed issue that live module unplug/replug sometimes corrupts I/O mapping - Fixed issue that re-installation attempt of language files sometimes causes an error message
EPXPNS001-AAAC	01.04.00	02.01.00	Nov 2017	<p>Enhancements and updates to Web Application</p> <ul style="list-style-type: none"> - Web Application: <ol style="list-style-type: none"> a. Added Tooltips for Coupler LEDs b. Improved arrangement of module parameters & general information

Catalog Number	Hardware Version	Firmware Version	Date	Comments
				<ul style="list-style-type: none"> c. Display of raw process data next to physical value d. Web application performance improved - "Disappearing" Diagnosis is not sent via Fieldbus when the module in front is pulled - New parameter to group the power supply error, filter return of submodule alarms - Filter diagnosis messages for bus error on hot plug
EPXPNS001-AAAB	01.04.00	01.00.04	Sep 2016	<ul style="list-style-type: none"> - Support for three new modules, EP-1804, EP-5261, and EP-5311 - Resolves a problem, see section <i>Problems Resolved by this Release</i> for more information
EPXPNS001-AAAA	01.04.00	01.00.04	Dec 2015	Documentation update only added known issues
EPXPNS001-AAAA	01.04.00	01.00.04	Nov 2015	Initial Release

Important Product Information for this Release

Updates

The product has undergone firmware updates for enhancements:- EPXPNS001LITE-AAAA The product may be upgraded in the field using the Web firmware upgrade kit, which can be downloaded from <http://pacsystems.co/support>.

Module	Firmware Version	Upgrade Kit & GSDML File
EPXPNS001LITE-AAAA	FW - 01.00.00	EPXPNS001LITE-0007675-01_00_00-6.zip which includes the following files: - <ul style="list-style-type: none"> a. EPXPNS001LITE-0007675-01_00_00-6.bsc b. GSDML-V2.33-IntelligentPlatforms-EPXPNS001LITE-20250220.xml c. FW Upgrade Procedure

Functional Compatibility EPXPNS001

HW Index [Ver]	FW Index [Ver]											
	AA [01.00.00]	AB [02.00.00]	AC [02.01.00]	AD [02.02.00]	AE [02.03.00]	AF [02.03.01]	AG [02.04.02]	AH [02.05.01]	AH [02.05.03]	AJ [02.06.02]	AK [02.06.04]	AL [02.06.05]
AA [01.04.00]	OK	OK	OK	OK	OK	OK	NO	NO	NO	NO	NO	NO
AB [01.05.00]	NO	NO	NO	OK	OK	OK	NO	NO	NO	NO	NO	NO
AC [01.05.00]	NO	NO	NO	OK	OK	OK	NO	NO	NO	NO	NO	NO
AD [02.00.00]	NO	NO	NO	NO	NO	NO	OK	OK	OK	OK	OK	OK
AE [02.00.00]	NO	NO	NO	NO	NO	NO	OK	OK	OK	OK	OK	OK
AF [02.00.00]	NO	NO	NO	NO	NO	NO	OK	OK	OK	OK	OK	OK

Problems Resolved by this Release

Subject	Description
N/A	N/A

New Features and Enhancements

Subject	Description
EPXPNS001LITE-AAAA	Initial release of EPXPNS001LITE <ul style="list-style-type: none"> • Supports max 16 active IO modules • Supports Media Redundancy Protocol (MRP) Client mode operation

Known Restrictions and Open Issues

Subject	Description
N/A	N/A

Operational Notes

Subject	Description
N/A	N/A

Product Documentation

RSTi-EP Slice I/O Module User Manual (GFK-2958)



RSTi-EP Slice I/O Functional Safety Module User Manual (GFK-2956)

Contact Information and Support Guide

Questions? We are here to help.

Before starting a case or making a call, try searching our Knowledge Base on the Customer Center website—it might have the answer you need right away.

If you have a question, try the following steps:

Search our Knowledge Base	Open a Support Ticket	Register for a Customer Account
 pacsystems.co/knowledge	 pacsystems.co/support	 pacsystems.co/signup

Other Helpful Links

Customer Center Home Page	Commercial Website	Contact Information
 pacsystems.co/customercenter	 pacsystems.co/commercial	 pacsystems.co/contactus

Emerson reserves the right to modify or improve the designs or specifications of the products mentioned in this manual at any time without notice. Emerson does not assume responsibility for the selection, use or maintenance of any product. Responsibility for proper selection, use and maintenance of any Emerson product remains solely with the purchaser.

© 2026 Emerson. All rights reserved.

Emerson Terms and Conditions of Sale are available upon request. The Emerson logo is a trademark and service mark of Emerson Electric Co. All other marks are the property of their respective owners.