

PACSystems™ RSTi-EP

MODBUS® NETWORK ADAPTER MODULE (EPXMBE001)

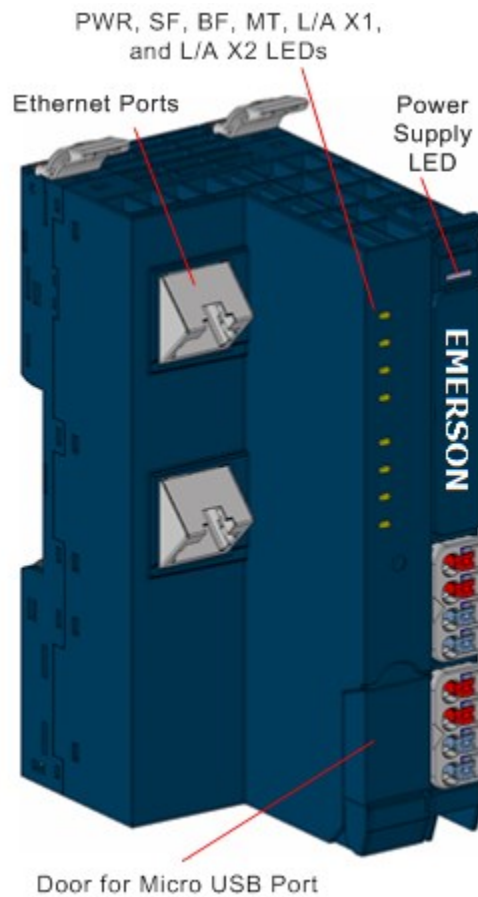

Warnings and Caution Notes as Used in this Publication

WARNING

Warning notices are used in this publication to emphasize that hazardous voltages, currents, temperatures, or other conditions that could cause personal injury exist in this equipment or may be associated with its use.

In situations where inattention could cause either personal injury or damage to equipment, a Warning notice is used.

CAUTION

Caution notices are used where equipment might be damaged if care is not taken.

Note: Notes merely call attention to information that is especially significant to understanding and operating the equipment.

These instructions do not purport to cover all details or variations in equipment, nor to provide for every possible contingency to be met during installation, operation, and maintenance. The information is supplied for informational purposes only, and Emerson makes no warranty as to the accuracy of the information included herein. Changes, modifications, and/or improvements to equipment and specifications are made periodically and these changes may or may not be reflected herein. It is understood that Emerson may make changes, modifications, or improvements to the equipment referenced herein or to the document itself at any time. This document is intended for trained personnel familiar with the Emerson products referenced herein.

Emerson may have patents or pending patent applications covering subject matter in this document. The furnishing of this document does not provide any license whatsoever to any of these patents.

Emerson provides the following document and the information included therein as-is and without warranty of any kind, expressed or implied, including but not limited to any implied statutory warranty of merchantability or fitness for particular purpose.

Product Description

The EPXMBE001 network adapter is a Modbus TCP participant developed according to IEC 61158. The network adapter is the head module for the RSTi-EP communication bus, to which up to 64 active RSTi-EP modules can be connected. The Modbus TCP network adapter has two Ethernet ports and an integrated switch.

The network adapter can be accessed with a system-independent web server application via the USB service interface or the Ethernet. Thus, all information, such as diagnostics, status values, and parameters, can be read and all connected modules can be simulated or forced.

The station's main power supply is integrated with the network adapter. Power is supplied via two 4-pole connectors, separated into the input and output current paths.

Caution, the RSTi-EP station is usually installed on a horizontally positioned DIN rail. Installation on vertically positioned DIN rails is also possible. However, the heat dissipation is reduced such that the derating values change (refer to the section, Thermal Derating).

Modules should be allowed to de-energize for a minimum of 10 seconds after powering down, before starting any maintenance activity. The network adapter cannot be hot-swapped.

Refer to the RSTi-EP Slice I/O User Manual (GFK-2958) for additional information.

Refer to the RSTi-EP Power Supply Reference Guide, a software utility available on PAC Machine Edition V9.00, for detailed power-feed requirements.

Module Features

- Supports up to 64 active RSTi-EP modules
- Spring-style technology for ease of wiring
- DIN rail mounted
- Double-click installation for positive indication of correct installation
- Built-in Web Server for diagnostic information and firmware update through Ethernet and micro USB port
- Option of fixed or DHCP IP address configuration
- Support for daisy-chain/line, star topologies

Ordering Information

| Module | Description |
|-----------|--|
| EPXMBE001 | RSTi-EP Slice I/O Modbus TCP Network Adapter |

Specifications

| Specification | EPXMBE001 | |
|-------------------------|--------------------|------------------|
| System data | | |
| Connection | 2 x RJ-45 | |
| Fieldbus protocol | Modbus TCP | |
| Process image | Input data width | max. 8 KB |
| | Parameter data | max. 1024 KB |
| | Diagnostic data | max. 1024 KB |
| Number of modules | max. 64 active | |
| Configuration interface | Micro USB 2.0 | |
| Transfer rate | Fieldbus | 10 Mbps/100 Mbps |
| | RTSi-EP system bus | Max. 48 Mbps |

| Supply | | |
|---|---|--|
| Supply voltage for system and inputs | 20.4 V – 28.8 V | |
| Supply voltage for outputs | 20.4 V – 28.8 V | |
| Max. feed-in current for input modules | 10 A | |
| Max. feed-in current for output modules | 10 A | |
| Current consumption from system current path I _{sys} | 112 mA | |
| Connection data | | |
| Type of connection | Spring style | |
| Conductor cross-section | Single-wired, fine-wired | 0.14 – 1.5 mm ² (AWG 26 – 16) |
| General data | | |
| Operating temperature | -20 °C to +60 °C (-4 °F to +140 °F) | |
| Storage temperature | -40 °C to +85 °C (-40 °F to +185 °F) | |
| Air humidity (operation/transport) | 5% to 95%, noncondensing as per IEC 61131-2 | |
| Width | 52 mm (2.05 in) | |
| Depth | 76 mm (2.99 in) | |
| Height | 120 mm (4.72 in) | |
| Weight | 223 g (7.87 oz) | |

LEDs

LED Status Indicators

| LED | Indication | LED State/Description |
|---|----------------------|---|
| PWR | Power LED | Green: Supply voltage connected |
| SF | System Fault | Red: Configuration error, or error in the network adapter, or error in a module, or there is a new diagnostic report Red flashing: Station in Force mode |
| BF | Bus fault | Red: No connection to the Fieldbus Red flashing: Configuration error, no connection to the control unit, or error in the parameter set |
| MT | Maintenance Required | Yellow: Error on the system bus or Fieldbus |
| L/A X1 | Connection/Active | Green / Yellow†: Connection established between port 1 of the network adapter and another field device Green flashing / Yellow flashing†: Data being exchanged on port 1 |
| L/A X2 | Connection/Active | Green: Connection established between port 2 of the network adapter and another field device Green flashing: Data being exchanged on port 2 |
| †Green: Transfer rate 100 Mbps Yellow: Transfer rate 10 Mbps | | |

LED Indicators



| LED | EPXMBE001 |
|--------------|--|
| Power Supply | Green: Supply voltage > 18 V DC Red: At least one current path < 18 V |

| LED | EPXMBE001 |
|-----|---|
| 3.1 | Green: Input current path supply voltage > 18 V DC |
| 3.2 | Red: Input current path supply voltage < 18 V DC |
| 3.3 | |
| 3.4 | Red: Internal fuse defective |
| 4.1 | Green: Output current path supply voltage > 18 V DC |
| 4.2 | Red: Output current path supply voltage < 18 V DC |
| 4.3 | |
| 4.4 | Red: Internal fuse defective |

Field Wiring

The connection frame has one connector, and two 24 V DC wires can be connected to each connector, along with two ground connections. Those four connectors are used as shown in the following figure. The Spring style technology allows either finely stranded or solid wire with crimped wire-end ferrules or ultrasonically welded wires, each with a maximum cross-section of 1.5 mm² (16 gauge), to be inserted easily through the opening in the clamping terminal without having to use tools. To insert fine stranded wires without wire-end ferrules, the pusher must be pressed in with a screwdriver and released to latch the wire.

Figure 1: Connector Block

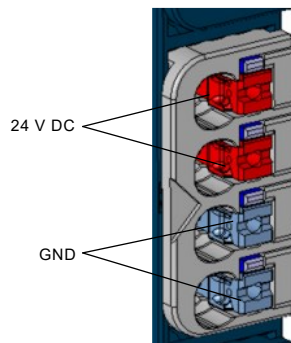

Connector Specifications:

- Conductor cross-section 0.14 to 1.5 mm² (26 – 16 gauge)
- Maximum ampacity: 10 A
- 4-pole

The modules do not have a fused sensor/activator power supply. All cables to the connected sensors/actuators must be fused corresponding to their conductor cross-sections (as per Standard DIN EN 60204-1, section 12).

Refer to the *RSTi-EP Slice I/O User Manual* (GFK-2958) for additional information.

For technical assistance, go to <http://pacsystems.co/support>

Connection Diagram

Figure 2: EPXMBE001

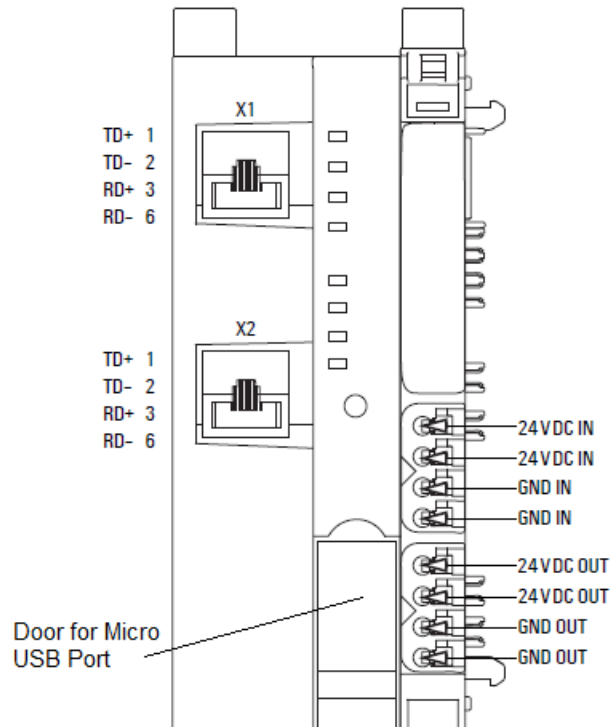

Connection Block Diagram

Figure 3: EPXMBE001

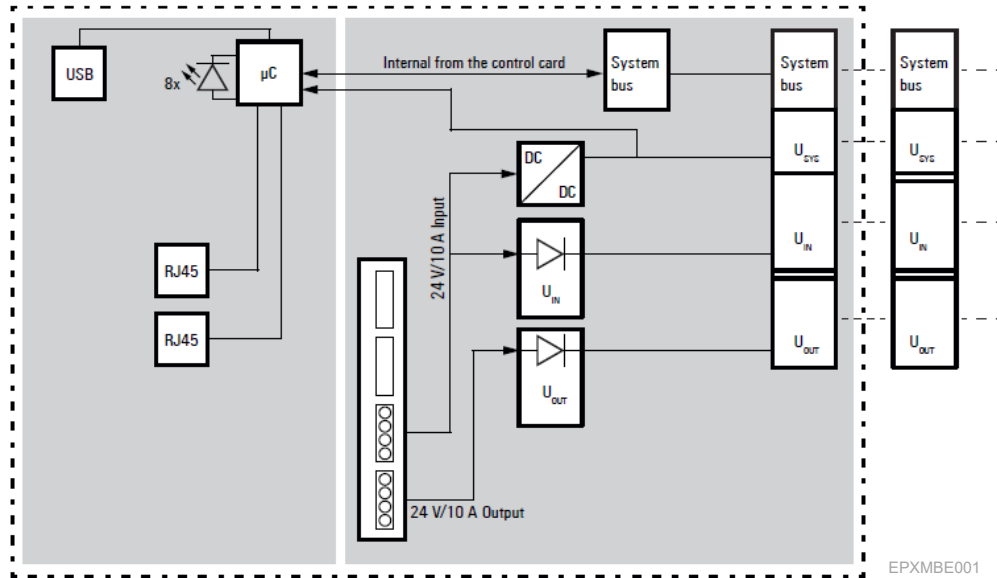

Installation in Hazardous Areas

⚠ WARNING

- EQUIPMENT LABELED WITH REFERENCE TO CLASS I, GROUPS A, B, C & D, DIV. 2 HAZARDOUS AREAS IS SUITABLE FOR USE IN CLASS I, DIVISION 2, GROUPS A, B, C, D OR NON-HAZARDOUS AREAS ONLY
- EXPLOSION HAZARD - SUBSTITUTION OF COMPONENTS MAY IMPAIR SUITABILITY FOR CLASS I, DIVISION 2;
- EXPLOSION HAZARD - WHEN IN HAZARDOUS AREAS, TURN OFF POWER BEFORE REPLACING OR WIRING MODULES; AND
- EXPLOSION HAZARD - DO NOT CONNECT OR DISCONNECT EQUIPMENT UNLESS POWER HAS BEEN SWITCHED OFF OR THE AREA IS KNOWN TO BE NONHAZARDOUS.

ATEX Marking

⊕ II 3 G Ex nA IIC T4 Gc

Ta: -20°C to +60°C (-4° F to +140 °F)

Thermal Derating

The power supply is restricted according to the temperature. The following values apply for the horizontal and vertical positioning of the RSTi-EP station:

Temperature-dependent Values for the Power Supply

| Power Supply | Horizontal | Vertical |
|--------------------------------|---|--|
| Network adapter power supply | 60°C (140 °F) : 2 x 8 A 55°C (131 °F) : 2 x 10 A | 55°C (131 °F) : 2 x 6 A 50°C (122 °F) : 2 x 8 A |
| Power-feed module power supply | 60°C (140 °F) : 1 x 10 A | 55°C (131 °F) : 1 x 8 A |

Refer to the RSTi-EP Slice I/O Module User Manual (GFK-2958) for additional information.

Supported Modules and Power Supplies

The following modules can be used with this release of the RSTi-EP Profibus Network Adaptor:

| Catalog Number | Module Description |
|-------------------------------------|---|
| Digital Input Modules | |
| EP-1214 | Digital Input, 4 Points, Positive Logic 24VDC, 2,3, or 4 Wire |
| EP-1218 | Digital Input, 8 Points, Positive Logic, 24VDC 2 Wire |
| EP-12A8 | Digital Input, 8 Points, Positive Logic, 2-Wire, Isolated |
| EP-1318 | Digital Input, 8 Points, Positive Logic, 24VDC 3 Wire |
| EP-125F | Digital Input, 16 Points, Positive Logic, 24VDC, 1 Wire |
| EP-153F | Digital Input, 16 Points, Negative Logic, 24VDC, 1 Wire |
| EP-12F4 | Digital Input, 4 Points, Positive Logic 24VDC, 2,3, or 4 Wire, Timestamp |
| EP-1804 | Digital Input, 4 Points 110/230 VAC (65 – 277 VAC), 2 Wire, Isolated |
| Digital Output Modules | |
| EP-2214 | Digital Output, 4 Points, Positive Logic 24VDC, 0.5A, 2,3, or 4 Wire |
| EP-22A4 | Digital Output, 4 Points, Positive Logic, 24VDC, 4A DC or 2A AC, 2 Wire, Isolated |
| EP-2614 | Digital Output, 4 Points, Positive Logic 24VDC, 2.0A, 2,3, or 4 Wire |
| EP-2634 | Digital Output, 4 Points, Positive/Negative Logic 24VDC, 2.0A, 2,3, or 4 Wire |
| EP-2218 | Digital Output, 8 Points, Positive Logic, 24VDC, 0.5A, 2 Wire |
| EP-225F | Digital Output, 16 Points, Positive Logic, 24VDC, 0.5A, 1 Wire |
| EP-291F | Digital Output, 16 Points, Negative Logic, 24VDC, 0.5A, 1 Wire |
| Digital Relay Output Modules | |
| EP-2714 | Digital Relay Output, 4 Points, Positive Logic, 24 - 220 VDC/VAC, 6A, 2 Wire |
| EP-2814 | Solid-state Relay Output Module |
| Analog Input Modules | |
| EP-3164 | Analog Input, 4 Channels Voltage/Current 16 Bits 2, 3, or 4 Wire |
| EP-3264 | Analog Input, 4 Channels Voltage/Current 16 Bits with Diagnostics 2, 3, or 4 Wire |
| EP-32A4 | Analog Input, 4 channels Isolated Voltage/Current 16 Bits with Diagnostics 2 Wire |
| EP-3124 | Analog Input, 4 Channels Voltage/Current 12 Bits 2, 3, or 4 Wire |
| EP-3368 | Analog Input, 8 Channels Current 16 Bits 2, 3, or 4 Wire |
| EP-3468 | Analog Input, 8 Channels Current 16 Bits 2, 3, or 4 Wire, Channel Diagnostic |
| EP-3664 | Analog Input, 4 Channels Voltage/Current 16 Bits with Diagnostics 2, 3, or 4 Wire, Differential Input |
| EP-3704 | Analog Input, 4 Channels RTD 16 Bits with Diagnostics 2, 3, or 4 Wire |
| EP-3804 | Analog Input, 4 Channels TC 16 Bits with Diagnostics 2, 3, or 4 Wire |
| EP-1813 | Power Measurement Module, 8 Channels |

| Catalog Number | Module Description |
|---|---|
| EP-3914 | Analog Input (Potentiometer), 4 Channels, 16 bits with Diagnostics, 3 wire or 3 wire connection +FE |
| Analog Output Modules | |
| EP-4164 | Analog Output, 4 Channels Voltage/Current 16 Bits 2, 3, or 4 Wire |
| EP-4264 | Analog Output, 4 Channels Voltage/Current 16 Bits with Diagnostics 2, 3, or 4 Wire |
| EP-42A2 | Analog Output, Isolated, 2 Channels Voltage/Currents 16 Bits Diagnostics 2-Wires |
| Speciality Modules | |
| EP-5111 | 1 Channel High Speed Counter, AB 100 kHz 1 DO 24VDC, 0.5A |
| EP-5112 | 2 Channel High Speed Counter, AB 100 kHz |
| EP-5212 | 2 Channel Frequency Measurement, 100 kHz |
| EP-5121 | 1 Channel High Speed Counter, AB 500 kHz |
| EP-5261 | 1 Channel Serial Communications, 232, 422, 485 |
| EP-5311 | 1 Channel SSI Encoder, BCD or Gray-Code Format, 5/24 VDC |
| EP-5422 | 2 Channels PWM Output, Positive Logic, 24VDC, 2.0 A |
| EP-5442 | 2 Channels PWM Output, Positive Logic, 24VDC, 0.5 A |
| EP-5324 | IO-Link Communication Module, 4 Channels |
| EP-5714 | 4 channels, Analog HART Input, Current 16 Bits with Diagnostics 2, 3, or 4 Wire |
| EP-5612 | 2 channels, Strain gauge, 24 Bits with Diagnostics 4 or 6 wire |
| EP-5501 | 1 Channel Stepper Motor, 2 phase. |
| Power Feed Modules for Input Current Path | |
| EP-7631 | Power Module, 1 Channel 24VDC Input Flow 10A |
| Power Feed Modules for Output Current Path | |
| EP-7641 | Power Module, 1 Channel 24VDC Output Flow 10A |
| Safe Feed-input Modules | |
| EP-1901 | 1 Safe Feed-Input, 24 VDC |
| EP-1902 | 2 Safe Feed-Inputs, 24 VDC, Programmable Delay |
| EP-1922 | 2 Safe Feed-Inputs, 24 VDC |
| Potential Distribution Modules | |
| EP-711F | Power Module, 16 Channels 24VDC Potential Distribution +24 VDC from Input Current Path |
| EP-751F | Power Module, 16 Channels 24VDC Potential Distribution +24 VDC from Output Current Path |
| EP-700F | Power Module, 16 Channels 24VDC Potential Distribution Functional Earth |
| EP-710F | Power Module, 16 Channels 24VDC Potential Distribution +0VDC from Input Current Path |
| EP-750F | Power Module, 16 Channels 24VDC Potential Distribution +0VDC from Output Current Path |
| Hot swap Modules | |
| EP-7990 | Bump less Output Hot-Swap Module |

Release History

| Catalog Number | Hardware Version | Firmware Version | Date | Comments |
|----------------|------------------|------------------|----------|---|
| EPXMBE001-AEAJ | 02.00.00 | 02.04.05 | Apr 2025 | - Updated firmware to support addition of IO modules - Release of PACSystems RSTi-EP DTM Library for EPXMBEx01 |
| EPXMBE001-AEAH | 02.00.00 | 02.04.04 | Nov 2024 | Updated Product marking to include CCC. |
| EPXMBE001-ADAH | 02.00.00 | 02.04.04 | Feb 2024 | - Firmware release 02.04.04 - Support for EP-7990 is added to enable bumpless hot-swap operation |

| Catalog Number | Hardware Version | Firmware Version | Date | Comments |
|----------------|------------------|------------------|----------|---|
| EPXMBE001-ACAG | 02.00.00 | 02.04.94 | Dec 2022 | Firmware release 02.04.94 |
| EPXMBE001-ACAF | 02.00.00 | 02.04.01 | May 2022 | Firmware release 02.04.01 |
| EPXMBE001-ACAE | 02.00.00 | 02.03.00 | Dec 2019 | Support for two newly introduced IO modules EP-1813 (Power Measurement module) and EP-5324 (IO-Link Communication Module) with only IPI update. |
| EPXMBE001-ACAE | 02.00.00 | 02.03.00 | Sep 2019 | <ul style="list-style-type: none"> - Following Emerson's acquisition of this product, changes have been made to apply appropriate branding and registration of the product with required certification agencies. No changes to material, process, form, fit or functionality. - Brand Labeling Web Application to EMERSON. - Updates to webserver:- <ul style="list-style-type: none"> - 'Ordering data is removed from the General Information section of Emerson branded products. - Improved module parameter setting dialogue in web application. - Factory reset over a Modbus-Register possible. |
| EPXMBE001-ABAD | 02.00.00 | 02.02.00 | Oct 2018 | <p>New features:</p> <ul style="list-style-type: none"> - The reset button appears automatically when changes in parameter settings require a restart to take effect - Added display of slot numbers to list of compatible modules after selecting a firmware file in multi-update view. - Added HTTPS support and new coupler parameter 'HTTPS settings'. [Available with Hardware version "AB" & above only in combination with firmware version "AD" & above] - Added password policy and weak password check - default username and password will remain the same - New languages for Web Server available. Korean, French, Spanish, Portuguese, and Italian - Support for EP-3664 <p>Issue Fixes:</p> <ul style="list-style-type: none"> - Fixed issue that live module unplug/replug sometimes corrupts I/O mapping - Fixed issue that re-installation attempt of language files sometimes causes an error message. |
| EPXMBE001-AAAD | 01.00.00 | 02.02.00 | Oct 2018 | <ul style="list-style-type: none"> - Added password policy and weak password check - default username and password will remain the same - New languages for Web Server available. Korean, French, Spanish, Portuguese, and Italian - Support for EP-3664 <p>Issue Fixes:</p> <ul style="list-style-type: none"> - Fixed issue that live module unplug/replug sometimes corrupts I/O mapping - Fixed issue that re-installation attempt of language files sometimes causes an error message. |
| EPXMBE001-AAAC | 01.00.00 | 02.01.00 | Nov 2017 | <p>Enhancements and updates to Web Application</p> <ul style="list-style-type: none"> - Configuring an additional TCP Port doesn't require a power cycle anymore & reconnection via an additional TCP port is possible now - Web Application: <ol style="list-style-type: none"> a. Tooltips for Network Adaptor LEDs b. Improved arrangement of module parameters & general information c. Display of raw process data next to a physical value d. Web application performance improved |

| Catalog Number | Hardware Version | Firmware Version | Date | Comments |
|----------------|------------------|------------------|----------|--|
| | | | | <ul style="list-style-type: none"> - Access to an illegal registered address is causing a diagnostic - Serial number of coupler available via Modbus - Module black list detection - coupler rejects incompatible modules |
| EPXMBE001-AAAB | 01.00.00 | 01.01.06 | Sep 2016 | <ul style="list-style-type: none"> - Support for three new modules, EP-1804, EP-5261, and EP-5311 - Resolves a problem, see section <i>Problems Resolved by this Release</i> for more information |
| EPXMBE001-AAAA | 01.00.00 | 01.01.06 | Dec 2015 | Documentation update only added known issues |
| EPXMBE001-AAAA | 01.00.00 | 01.01.06 | Nov 2015 | Initial Release |

Important Product Information for this Release

Updates

The product has undergone firmware updates for enhancements :- EPXMBE001-AEAJ The product may be upgraded in the field using the Web firmware upgrade kit, which can be downloaded from <http://pacsystems.co/support>

| Module | Firmware Version | Upgrade Kit |
|----------------|------------------|---|
| EPXMBE001-AEAJ | FW - 02.04.05 | EPXMBE001-0007675-02_04_05-6.zip which includes the following files: - a. EPXMBEx01-0007675-02_04_05-6.bsc b. FW Upgrade Procedure |

Functional Compatibility

| HW Index [Ver] | FW Index [Ver] | | | | | | | | |
|--|----------------|---------------|---------------|---------------|---------------|---------------|---------------|---------------|---------------|
| | AA [01.01.06] | AB [02.00.00] | AC [02.01.00] | AD [02.02.00] | AE [02.03.00] | AF [02.04.01] | AG [02.04.94] | AH [02.04.04] | AJ [02.04.05] |
| AA [01.00.00] | OK | OK | OK | OK | NO | NO | NO | NO | NO |
| AB [02.00.00] | NO | OK | OK | OK | OK | OK | OK | OK | OK |
| AC [02.00.00] | NO | OK | OK | OK | OK | OK | OK | OK | OK |
| AD [02.00.00] | NO | OK | OK | OK | OK | OK | OK | OK | OK |
| AE [02.00.00] | NO | OK | OK | OK | OK | OK | OK | OK | OK |
| <ol style="list-style-type: none"> 1. For HW version AAAD [01.00.00], use EPXMBE101-0007675-02_02_00-3.bsc file. This file is not compatible with HW version ABXX [02.00.00]. 2. For HW version ABAD [02.00.00], use EPXMBE001-0007669-02_02_00-2.bsc file. This file is not compatible with HW version AAXX [01.00.00]. | | | | | | | | | |

Problems Resolved by this Release

| Subject | Description |
|---------|-------------|
| N/A | N/A |

New Features and Enhancements

| Subject | Description |
|-----------------------------------|--|
| PACSystems RSTi-EP DTM Library | Release of DTM file for EPXMBE001/101 and EP-5714 to support HART. |

Known Restrictions and Open Issues

| Subject | Description |
|---------|-------------|
| N/A | N/A |

Operational Notes

| Subject | Description |
|---------|-------------|
| N/A | N/A |

Product Documentation

RSTi-EP Slice I/O Module User Manual (GFK-2958)



RSTi-EP Slice I/O Functional Safety Module User Manual (GFK-2956)

Contact Information and Support Guide

Questions? We are here to help.

Before starting a case or making a call, try searching our Knowledge Base on the Customer Center website—it might have the answer you need right away.

If you have a question, try the following:

| Search our Knowledge Base | Open a Support Ticket | Register for a Customer Account |
|--|--|--|
|  pacsystems.co/knowledge |  pacsystems.co/support |  pacsystems.co/signup |

Other Helpful Links

| Customer Center Home Page | Commercial Website | Contact Information |
|--|--|--|
|  pacsystems.co/customercenter |  pacsystems.co/commercial |  pacsystems.co/contactus |

Note: If the product is purchased through an Authorized Channel Partner, please contact the seller directly for any support.

Emerson reserves the right to modify or improve the designs or specifications of the products mentioned in this manual at any time without notice. Emerson does not assume responsibility for the selection, use, or maintenance of any product. Responsibility for proper selection, use, and maintenance of any Emerson product remains solely with the purchaser.

© 2025 Emerson. All rights reserved. Emerson Terms and Conditions of Sale are available upon request. The Emerson logo is a trademark and service mark of Emerson Electric Co. All other marks are the property of their respective owners.