

Quick Start Guide  
GFK-3268B  
Jul 2024

# PACSystems™ IPC 2010

## QUICK START GUIDE



# Contents

## Initial Checks 1

### Front Panel Description..... 2

Power-Input..... 3

Battery..... 5

    Battery Maintenance..... 6

Serial Console..... 7

Secure Shell (SSH)..... 8

IP-Addresses ..... 8

### Pre-Installed Software Images ..... 9

    Ubuntu Server Quick Start..... 10

        Default User and Passwords ..... 10

        Networking Configuration ..... 11

        Additional network configuration..... 12

    PACEdge Quick Start ..... 13

        Getting Started..... 14

        Initial Login..... 14

### Additional Information..... 18

    WiFi/Cellular Module with PACEdge ..... 18

    Overtemperature Alarm ..... 21

    LED Control ..... 22

    Accessing the Boot Loader ..... 22

### Additional Information..... 23

    General Contact Information..... **Error! Bookmark not defined.**

# Initial Checks

Upon receiving your equipment, carefully inspect all shipping containers for damage. If any part of the system is damaged, notify the carrier immediately. The damaged shipping container should be saved as evidence for inspection by the carrier.

As the consignee, it is your responsibility to register a claim with the carrier for damage incurred during shipment. Emerson will fully cooperate with you, however, should such action be necessary.

After unpacking the equipment, record all serial numbers. Serial numbers are required if you should need to contact Customer Care during the warranty period. All shipping containers and all packing material should be saved should it be necessary to transport or ship any part of the system.

Verify that all components of the system have been received and that they agree with your order. If the system received does not agree with your order, contact Customer Care.

# Front Panel Description

Figure 1: Overview



Number	Description
1	Power & Temperature LED
2	μSD Card slot
3	USB-C port
4	Serial port
5	USB ports
6	Ethernet ports
7	Power Connector

## Power Input (IPC2010)

To power the system, a voltage of 24 V DC must be supplied to the power connector. The IPC2010 power supply must meet the requirements for SELV (safety extra-low voltage)/LPS (limited power source) or ES1/PS2 appropriately rated for the ambient and altitude of the application. There are no buttons for power or resetting, as the system will start automatically once power is applied. The Power LED (1) will light up green to indicate that the system is now powered on.

The specific plug required is a Phoenix Contact with part number 1748367, and users must use the same connector type

---

**Figure 2: Power Input**

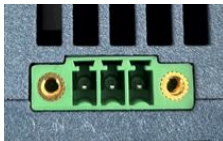

Signal Name	Pin (left to right)
FGND	1
Power – 24VDC (10-30VDC)	2
Power + 24VDC (10-30VDC)	3

## Power Input 4G/WiFi Kit (if present)

To power the system, a voltage of 9V-30V DC must be supplied to the power connector via power adapter cable via screw terminals: pin 1 – VCC, pin 2 - GND. The IPC 2010 power supply must meet the requirements for SELV (safety extra-low voltage)/LPS (limited power source) or ES1/PS2 appropriately rated for the ambient and altitude of the application. It is recommended to use a power supply that is rated for at least 10W power delivery.

---

**Figure 3: Power Supply**

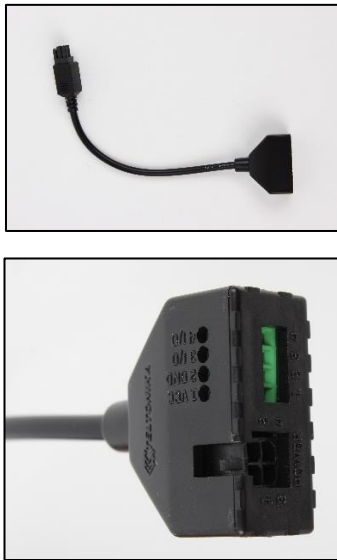

## CAUTION

Equipment is intended for installation in Restricted Access Area.

Les matériels sont destinés à être installés dans des  
EMPLACEMENTS À ACCÈS RESTREINT.

---

## Battery

The IPC 2010 contains a CR2032 lithium coin battery. It is an industrial CR2032 (-40 °C to 125 °C) battery and is accessible on the right side of the IPC2010. Depending on the operating hours and temperature, the estimated battery life is between 2 to 10 years. Battery current is not used when the IPC2010 is supplied with 24 V.

## Battery Maintenance

To replace the battery, pull the battery holder (on the right side of the system) out of the system, replace the battery, and insert the battery holder back into the system.

**Figure 4: Battery Removal**

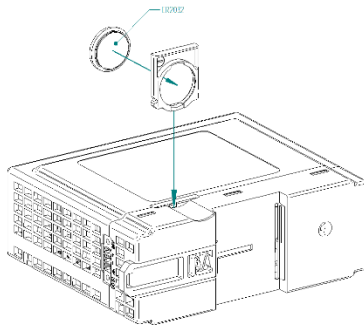

### **⚠ CAUTION**

- Only replace with CR2032 battery. Batteries may explode if mistreated. Do not charge, disassemble, or incinerate.
- Remplacer uniquement par une pile CR2032. Les piles peuvent exploser si elles sont maltraitées. Ne pas charger, démonter ou incinérer.

## Serial Console

To gain access to the system, utilize the serial console port (4) by connecting it to the host PC's RS232 interface using a null modem cable. Once connected, the host can establish a connection by running a terminal emulator such as HyperTerminal or Minicom. The default serial port parameters are **115200, 8N1**

The connector is RJ-45 style with pinout as defined in EIA/TIA-561, so that off-the-shelf adapters to DB9 or USB can be used.

The pinout for RJ-45 (8P8C) connector is defined as follows:

Signal	RJ-45 Pin
GND	4
RxD	5
TxD	6

Once a serial connection is established, it can be used to determine an IP address that was assigned by the DHCP server, using the command:  
**ip addr**

## Secure Shell (SSH)

To establish a connection with the system, Ethernet can be used instead of the serial console. The system has an SSH server running on port 22, and the default IP address settings are described below.

To connect to the system, use Putty on a Windows host or the default SSH tools on Linux.

The login credentials will vary depending on the pre-installed software \*Ubuntu Linux or PACEdge), so it is advised to refer to the sections below for specific details.

## IP-Addresses

On preinstalled systems, the second ethernet interface (Port 2) is configured to use the static IP-Address: **192.168.3.100** and DHCP as well. Therefore (if the second ethernet interface is connected to a DHCP server) two IP addresses are usable on this interface (IP-Address provided by the DHCP server and static IP-Address 192.168.3.100).

### CAUTION

MULTIPLE DEVICES WITH THE SAME IP ADDRESS ON THE SAME NETWORK CAN LEAD TO ADDRESS CONFLICTS WITH UNPREDICTABLE BEHAVIOR.

If you are using several Micro IPC devices in the same network, it is **strongly recommended** to change the static IP Address.

# Pre-Installed Software Images

IPC 2010 comes with two pre-installed software options:

- Ubuntu Server 20.04.05 LTS
- PACEdge v2.3.0 (based on Ubuntu 20.04 Server)

Depending on pre-installed software login credentials, some of the configuration tasks are different. The sections below will guide you through the getting started process for each of these software options.

# Ubuntu Server Quick Start

Ubuntu Server 20.04.05 LTS software package provides a basic Linux operating system environment on IPC 2010. Software installation contains only basic software packages, but user can easily install additional packages by using **apt** command.

## Default User and Passwords

Default Username	<b>ubuntu</b>
Default Password	<b>ubuntu</b>

**Note:** This user also has sudo permissions to be able to execute privileged operations and to install additional software packages using **apt** command.

## Networking Configuration

In Ubuntu Server, the interface **Port 1** is named **lan1**, the interface **Port 2** is named **lan0**.

### CAUTION

MULTIPLE DEVICES WITH THE SAME IP ADDRESS ON THE SAME NETWORK CAN LEAD TO ADDRESS CONFLICTS WITH UNPREDICTABLE BEHAVIOR.

If you are using several microIPC devices in the same network, it is **strongly recommended** to change the static IP Address.

---

The static IP-Address can be configured in the following files:

Interface 1	<i>/etc/netplan/20-eth1.yaml</i>
Interface 2	<i>/etc/netplan/10-eth0.yaml</i>

## Additional network configuration

If the system obtains an IP address via DHCP, the server may supply additional information like DNS server addresses or the default gateway to configure the client system.

If this is not the case, or when using manual IP configuration, some additional settings must be made to obtain full network functionality.

Setting the default gateway:

```
ip route set default via <address>
```

Setting a DNS server:

```
resolvectl dns lan0 <server address>
```

Permanent network configuration is done via netplan and its configuration files in /etc/netplan/. Activate the new configuration after making changes with:

```
netplan apply
```

# PACEdge Quick Start

PACEdge version 2.3.0 software package is a data acquisition, analytics, and visualization platform based on Ubuntu 20.04 Linux. The following sections will describe the steps to get started. For additional information please consult PACEdge v2.3.0 User Manual.

On IPC 2010 PACEdge operates in a headless mode with the user accessing it remotely via Ethernet using a web interface.

**Figure 5: Use Case Model**

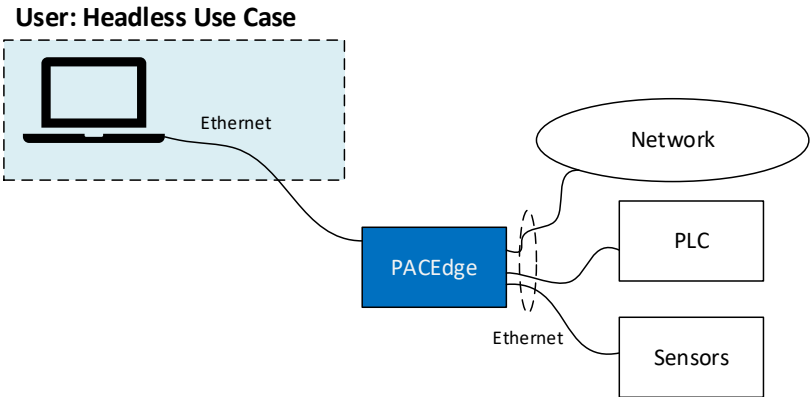

## Getting Started

1. Connect the Ethernet cable to the Ethernet port labeled Port2.
2. Setup the User PC Ethernet port IP address to be statically assigned as follows:

**Pv4 Static IP: 192.168.3.10**  
(or similar in the same subnet)

**a. Netmask: 255.255.255.0**

1. Power up the IPC (please consult initial startup section for details) and wait until it boots.
2. Open the browser of your choice and type in **192.168.3.100** in the address bar.

**Note:** All Ethernet ports are also configured to get IP addresses assigned by the DHCP server. This dynamically assigned IP address can also be used to access PACEdge.

## Initial Login

Upon connecting to PACEdge for the first time, a warning message may display due to the self-signed certificate on the device. The message will state that the identity of the device could not be confirmed. To proceed please click on **Advanced** and **Accept**.

Please read and accept the Emerson End User License Agreement (EULA).

Once EULA has been accepted you will be redirected to the Password Management screen. PACEdge software consists of multiple software tools and applications, each having its user management and password settings. To simplify the process, PACEdge comes with pre-configured users: *admin*, *developer*, *service*, and *operators*, each having its password. Use the Password Management screen to change passwords in two steps: 1) for all PACEdge Applications, 2) for Cockpit/Linux (Figure 6). When changing the passwords, follow instructions on the screen and consult help information accessible via the question mark button in the upper right corner.

**Note:** For cybersecurity reasons and for proper user account setup, the user **must** change the default passwords at the first login.

---

### **Important**

Please consult the PACEdge Secure Deployment Guide (GFK-3197) for recommended password changes and other cybersecurity-relevant settings

---

**Figure 6: Password Management Screen (top portion: PACEdge Applications, bottom portion: Cockpit/Linux)**

**EMERSON** | Emerson PACEdge

Services

### Password Management

#### Manage PACEdge Application Passwords

Admin password  Admin Credentials

Login Name	Action	Password
admin	<a href="#">Please change Password</a>	<input type="password"/>
developer	<a href="#">Please change Password</a>	<input type="password"/>
service	<a href="#">Please change Password</a>	<input type="password"/>
operators	<a href="#">Please change Password</a>	<input type="password"/>
admin@edgestack.com (used in Movicon Project Deploy)	<a href="#">Please change Password</a>	<input type="password"/>

#### User Rights Overview

#### Manage Cockpit/Linux Passwords

Cockpit/Linux Password Management:

**PACEdge** | Version: V2.2.0 | Headline | 000 Info

Once the passwords have been changed, click on the Emerson logo in the upper-left corner. The logo is a shortcut to the PACEdge Landing Page, which has further shortcuts to Node-RED, Grafana, Cockpit, Portainer, and other applications. The user can return to the Password Management screen from the PACEdge landing page by clicking **Password Management** in the Settings drop-down list on the right side.

**Figure 7: PACEdge Landing Page**

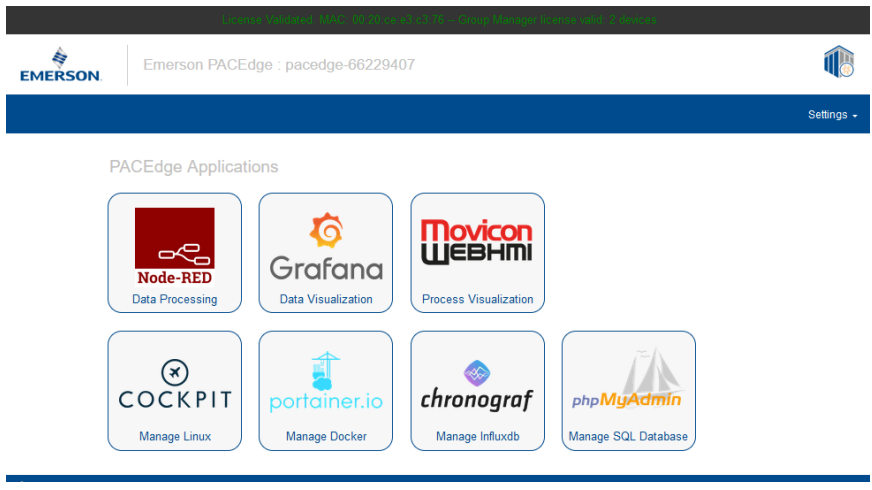

To explore PACEdge, click on Node-RED and log in with:

- **user:** admin
- **password:** edgestack (or the password that was set on the Password Services page)

Start exploring example flows or create your own flows. Consult the PACEdge User Manual (GFK-3178) for example details.

**Important:** Please consult the PACEdge Secure Deployment Guide (GFK-3197) for recommended password changes and other cybersecurity-relevant settings.

## Additional Information

### WiFi/Cellular Module with PACEdge

When using Teltonika RUT241 WiFi/Cellular module, use the following steps for the configuration:

1. Download RUT241 Quick Start Guide from address:  
**<https://wiki.teltonika-networks.com/view/RUT241>**
2. If Cellular connectivity is required, obtain SIM card and install it into RUT241 device

- Note the password written on the back side of the RUT241 and remove the plastic holding bracket to see it.



- Attach the cables to the two mobile connectors and one Wi-Fi antenna connector.



- Power up RUT241 by using the included power cable adapter. The allowed power voltage range is 9V-30V.
- Connect the Ethernet cable between the RUT241 LAN port and one of the unused Ethernet ports on the PACEdge device.



- Using Cockpit, make sure that the chosen Ethernet port on the PACEdge is configured for automatic DHCP operation.

8. Using Cockpit, open Terminal and issue the following command:  
**ssh -g -L 1180:192.168.1.1:80 admin@localhost**  
Accept the connection and enter the PACEdge administrator's username and password as requested.)
9. On your PC, open a browser and enter the PACEdge device IP address, followed by port number **1180**. For example:  
**http://192.168.3.100:1180**
10. Next you will see Teltonika login screen. Please log in using the password that you have noted in the previous step:  
**user: admin**  
**password:** (as printed on the back of the device)
11. Follow the instructions to change your password.
12. Next, a wizard will guide you through configuring the modem. To set up RUT241 as a WiFi Access Point and LAN bridge to the internet using a cellular network, follow the default settings recommended by the wizard. Here are some notes to configure your time zone:
  - a. Keep default settings for LAN and DHCP configuration
  - b. Enter your SIM card pin
  - c. If necessary, change the WiFi AP SSID name and enter the desired WiFi password

- d. Keep the remaining default settings. When finished, observe connectivity to the cellular network via your provider of choice.
13. At this point PACEdge device can access the Internet via Cellular Modem.

**Note:** The default configuration also has created a WiFi Network, which other devices can connect to and can access the Internet via the modem.

## Overtemperature Alarm

To protect the system from damage and avoid unpredictable behavior, the device will shut down when a temperature limit is reached (the actual limit depends on the system variant).

When this limit is reached, the system will shut down and the Temperature LED (2) will light up in red.

The system will restart automatically after the temperature has fallen below the threshold hysteresis.

## LED Control

If a user needs to control LED behavior directly, this can be achieved in Linux using the pseudo-files located in

*/sys/class/leds/*





## Accessing the Boot Loader

The boot loader of IPC2010 is configured to start the installed Linux OS automatically without user interaction.

If it is necessary to access the boot loader settings or change the boot process, a serial connection cable as described above is required to access the U-boot console.

# Contact Information and Support

Questions? We are here to help.

<b>Search our Knowledge Base</b>	<b>Open a Support Ticket</b>	<b>Register for a Customer Account</b>
 <a href="https://pacsystems.co/knowledge">pacsystems.co/ knowledge</a>	 <a href="https://pacsystems.co/support">pacsystems.co/support</a>	 <a href="https://pacsystems.co/signup">pacsystems.co/ signup</a>
<b>Customer Center Home Page</b>	<b>Commercial Website</b>	<b>Contact Information</b>
 <a href="https://pacsystems.co/customercenter">pacsystems.co/ customercenter</a>	 <a href="https://pacsystems.co/commercial">pacsystems.co/ commercial</a>	 <a href="https://pacsystems.co/contactus">pacsystems.co/ contactus</a>