

Installation Drawing for the 8201-HI-IS 8-Channel Analogue Input Module, with HART

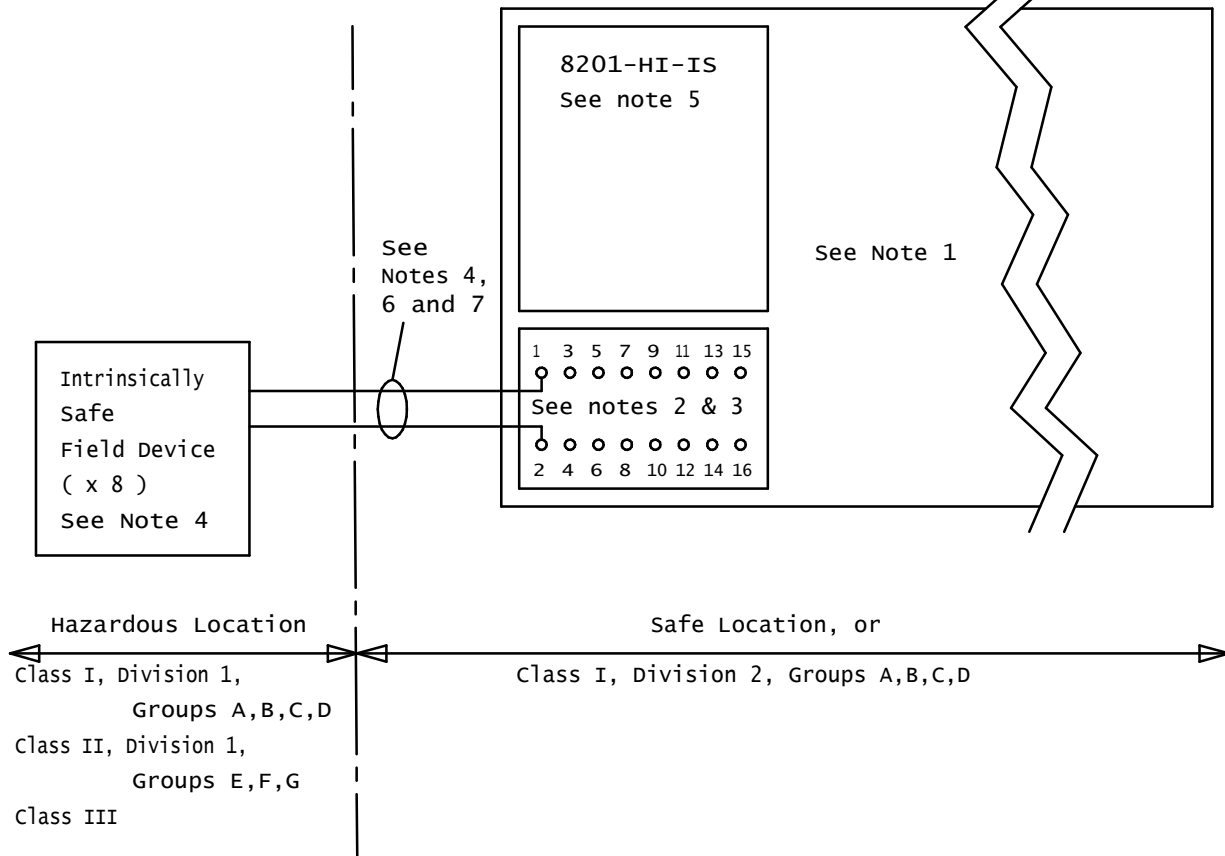

Notes

1. The 8201-HI-IS Analogue Input Module, with HART, may only be mounted on either the 8720-CA-04 or the 8727-CA-08 I/O module carriers.
2. The 8201-HI-IS may be used in conjunction with either the 8621-FT-IS or the 8622-FT-IS Field Terminal Assemblies.
3. Each of the eight output channels of the 8201-HI-IS uses one pair of terminals of the above Field Terminal Assemblies.

Ch. No.	Terminals
1	1 and 2
2	3 and 4
3	5 and 6
4	7 and 8
5	9 and 10
6	11 and 12
7	13 and 14
8	15 and 16

Each pair of terminals has the following entity parameters

$U_o \leq 28Vdc$ $I_o \leq 93mA$ $P_o \leq 0.65W$

Group A,B	Groups C,E	Groups D,F,G
$C_a \leq 0.14\mu F$	$C_a \leq 0.43\mu F$	$C_a \leq 1.14\mu F$
$L_a \leq 4.38mH$	$L_a \leq 17.2mH$	$L_a \leq 34.2mH$

4. Each channel of the 8201-HI-IS may be connected to apparatus which does not generate or store more than 1.2V, 0.1A, 25mW or 40μJ, such as switches, thermocouples, LEDs and RTD devices, provided cable parameters meet the following criteria:-

$$C_a \geq C_{cable}$$

$$L_a \geq L_{cable}$$

Alternatively, each channel of the 8201-HI-IS may be connected to FM-approved intrinsically safe apparatus suitable for use in use in Division 1 hazardous locations in accordance with the following criteria:-

$$V_{oc} \geq \text{Apparatus } V_{max}$$

$$I_{sc} \geq \text{Apparatus } I_{max}$$

$$C_a \leq C_i + C_{cable}$$

$$L_a \leq L_i + L_{cable}$$

5. The 8201-HI-IS may be removed from or inserted onto the carrier whilst the carrier remains energised. It is preferable if removal and insertion are performed when the area is known to be non-hazardous.
6. Each of the field devices, and associated wiring, connected to the 8201-HI-IS shall satisfy the 500Vdc insulation test to field devices connected to any other 8000 Series I/O module, forming part of the same installation.
7. Field wiring devices must be installed in accordance with the requirements of ANSI/ISA RP12.6.