

PACSystems™

IC695CPE400 64 MB Rackless CPU with
PACEdge + Connext

IC695CPL410 64 MB Rackless CPU with
PACEdge + WebHMI

QUICK START GUIDE

GFK-3053K

Dec 2024



Contents

Contents	i
Introduction	1
Front Panel Description	1
Switches	2
Displays and Indicators (LEDs)	3
OLED Display	3
Status Indicators (LEDs)	4
Front Ethernet Indicators (LAN1, LAN2, LAN3 RJ45 Built-in LEDs)	6
Bottom Ethernet Indicators (PACEEdge RJ45 Built-in LED)	6
Interfaces and Connectors	7
Front-Panel Ethernet Ports	8
PACEEdge Port	9
Serial COM Port	9
Video DisplayPort	9
Energy Pack Connector	11
Input Power Connector	11
Removable Data Storage Device (RDSD)	11
Hardware Installation	11
Initial Checks	11
Installation	12
Installation in Hazardous Areas	12
Connect to Power Supply	13
Module Start-up	15
Equipment Needed	15
Basic Start-up Steps	17
CPL410/CPE400 PLC Configuration	18
Backwards Compatibility	18
PROFINET Controller Configuration	18
Redundancy Configuration	20
PACEEdge	21
PACEEdge +ConnexT	21
PACEEdge +WebHMI	22
PACEEdge Quick Start	22
Factory Reset	28
Additional Information	29
General Contact Information	30

Introduction

The PACSystems™ RX3i CPL410/CPE400 deploys with PACEdge, which is Emerson's software suite for data analytics and visualization.

Front Panel Description

Figure 1: Display, Lights, and Connectors on the CPL410/CPE400

OLED Display

- LAN Settings
- Control Status
- I/O Status
- Device Info
- Linux Settings
- Redundancy (RDN) Info
- Redundancy (RDN) Commands

TPM Physical Presence Indication/Select (Phy Pres)

(Green = Present)

Solid State Disk Activity (SSD)

(Green = Activity)

Overtemperature (TEMP)

(Amber = Overtemperature)

Active Redundant Unit (RACT)

(Green = Active)

Redundant Backup Unit OK (RBOK)

(Green = OK)

General Purpose OK (GPOK)

(Blinking Green = PACEdge Running)

Underside Ports and Connectors

Micro-SD Card Slot (Side) & Protective Cover

Display Menu Navigation (DISP)

Display Menu Selection (SEL)

Run Mode Selection

PLC Mode Indication

(Green = Run)

STOP Mode Selection

CPU OK (OK)

(Green = OK)

Outputs Enabled (OE)

(Green = OK)

Force Applied (FRC)

(Yellow = Enabled)

System Fault Present (FLT)

(Red = Fault Present)

I/O Network Status (IO)

(Green = OK)

Power/Reset (PWR)

(Green = Power On)
Button - Hold for Reset

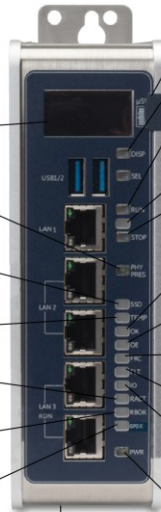

Switches

All user-accessible switches are provided as pushbuttons on the front panel as described below.

Pushbutton	Function
DISP	Permits user to navigate menus in the OLED display.
SEL	Permits user to select the menu item on the OLED display.
RUN	Activates OLED Menu to select RUN/Enabled or RUN/Disabled Mode for the embedded PLC.
STOP	Activates OLED Menu to select STOP/Enabled or STOP/Disabled Mode for the embedded PLC.
PHY PRES	Not functional.
PWR	Hold down for brief period to induce CPU Reset. Note that this does not turn unit power off, but only holds unit in Reset

Displays and Indicators (LEDs)



















OLED Display

The monochrome organic light-emitting diode (OLED) display is used to display CPL410/CPE400 system menus. It interacts with the DISP pushbutton, which jogs the cursor from one menu item to the next, and with the SEL pushbutton, which activates the currently indicated menu item for further action.















The OLED display permits the user to:

- Display Ethernet LAN Settings: IPv4 address.
- Display the PLC firmware revision.
- Set/view PLC mode and view sweep time.
- Set the PLC mode to RUN/STOP with I/O Enabled/Disabled via the display. **Note:** the RUN and STOP pushbuttons activate the PLC Mode menu items per section switches.
- View whether all, some, or none of the PROFINET I/O devices are connected.
- Display PACEdge Settings: IPv4 address, subnet mask, gateway, MAC address, IPv6 address.
- Issue PACEdge Commands: Enter/Exit Configuration mode, Clear Configuration, Perform factory reset.
- View HSB Redundancy Mode and State (Release 9.30 and later)
- Command an HSB Redundancy Role Switch (Release 9.30 and later)





Status Indicators (LEDs)

LED	LED State	Operating State
PLC MODE ¹	 On Green	PLC is in RUN mode.
	 Off	PLC is in STOP mode.
RUN OE	  Blinking in unison	CPU is updating an internal programmable hardware device.
PHY PRES	 On Green	TPM Physical Presence (not functional).
	 Off	
SSD	 On Green	Activity detected on Solid State Disk.
	 Off	No activity detected on Solid State Disk.
TEMP	 On Red	CPU Overtemperature condition detected.
	 Off	Overtemperature condition not detected.
OK	 On Green	CPU has passed its power-up diagnostics and is functioning properly. <i>(Following initialization sequence.)</i>
	 Off	Power is not applied, or CPU has a problem.
	 Blinking; All other LEDs off	PLC in STOP/Halt state; possible watchdog timer fault. If the programmer cannot connect, cycle power with charged Energy Pack attached and refer to fault tables.
OK OE	  Blinking alternately	CPU encountered a Secure Boot Error.
OE	 On Green	Output scan is enabled.
	 Off	Output scan is disabled.
FRC	 On Yellow	One or more Overrides active in I/O Reference Table(s).







¹ This LED is located between the RUN and STOP pushbuttons. It indicates the PLC Mode.

LED	LED State	Operating State
	 Off	No Overrides active in any I/O Reference Table.
FLT	 On Red	PLC is in STOP/Faulted mode: a fatal fault has occurred.
	 Off	No fatal faults detected.
IO	 On Green	PROFINET Connection Status = OK.
	 Off	PROFINET Connection Status not OK.
RACT	 On Green	Local Redundant CPU is Ready & Active.
	 Off	Local Redundant CPU is not Ready.
RBOK	 On Green	Remote Redundant CPU is Ready.
	 Off	Remote Redundant CPU is not Ready.
GPOK	 On Green	PACEdge Running.
	 Off	PACEdge not running.
PWR	 On Green	CPU running.
	 Blinking Green	Booting up – diagnostics in progress.
	 On Red	Off
	 Off	Reset / Power not detected.

Front Ethernet Indicators (LAN1, LAN2, LAN3 RJ45 Built-in LEDs)

LED	LED State	Operating State
Link Status (upper)	 On Green	The corresponding link has been established.
	 Blinking Green	Traffic is detected at the corresponding port.
	 Off	No connection established at corresponding port.
Link Speed (lower)	 On Green	Corresponding data speed is 1 Gbps or 100 Mbps.
	 Off	Corresponding network data speed is 10 Mbps

Bottom Ethernet Indicators (PACEdge RJ45 Built-in LED)

LED	LED State	Operating State
Link Status (upper)	 On Green	The corresponding link has been established.
	 Blinking Green	Traffic is detected at the corresponding port.
	 Off	No connection established at corresponding port.
Link Speed (lower)	 On Green	Corresponding network data speed is 1 Gbps.
	 On Yellow	PACEDGE port only: network data speed is 100 Mbps
	 Off	Corresponding network data speed is 10 Mbps

Module Identification LED Pattern

The LEDs on a CPL410/CPE400 can be commanded to repeatedly turn ON and OFF in a special sequence through LAN 2 to help locate or identify the module when PROFINET is enabled. This pattern is initiated by the PROFINET DCP Identify Device command which is available using the PAC Machine Edition Discovery Tool by refreshing the device list, double clicking on the CPE400/CPL410 row, and pressing the Identify Device button on the Device Properties pop-up window. The pattern on the CPE400/CPL410 is a rising and falling vertical bar made up of:

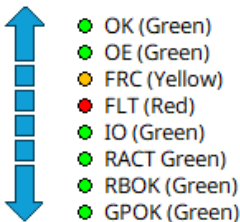

The LEDs are turned on from the bottom until all are illuminated and then they are turned off in the reverse order to generate a 1Hz cycle that is repeated until the Identify Device command is stopped.

Interfaces and Connectors

USB Ports

On the front panel CPL410/CPE400 features 2 USB 3.0 ports, labeled USB1 and USB2.

- USB1 is assigned to PACEdge and can be used for storage devices. For other USB devices an appropriate Linux driver will need to be installed.
- USB2 is assigned to the Controller run time PACS.

Front-Panel Ethernet Ports

LAN1 connects to the uppermost RJ45 connector. It is not switched.

LAN2 connects to the middle two RJ45 connectors. These two ports are switched internally.

LAN3 connects to the two lower RJ45 connectors. These two ports are switched internally. LAN3 may only be used to supply a high-speed synchronization link between the Primary and Secondary CPUs in Hot Standby Redundancy. Both ports are typically used, as described in the *PACSystems Hot Standby CPU Redundancy User Manual*, GFK-2308 (revision L or later).

Each of the embedded Ethernet interfaces automatically senses the data rate (10 Mbps or 100 Mbps or 1 Gbps), communications mode (half-duplex or full-duplex), and cabling arrangement (straight-through or crossover) of the attached link. LEDs embedded in each RJ45 connector provide indications per the table above.

LAN1 or LAN2 may be used to communicate with the PME programming software using the Service Request Transport Protocol (SRTP).

To establish Ethernet communications between the PME programming and configuration software and the CPU, the user will *first* need to know the target IP address. Use the OLED menu function to check the IP Address. The factory-shipped settings are:

	CPL410/CPE400 LAN1	CPL410/CPE400 LAN2	CPL410/CPE400 LAN3
IP Address:	192.168.0.100	10.10.0.100	N/A
Subnet Mask:	255.255.255.0	255.255.255.0	N/A
Gateway:	0.0.0.0	0.0.0.0	N/A

PACEdge Port

The RJ45 port, marked ETH, is located on the underside of the CPL410/CPE400, as shown in Figure 2. This Ethernet port is exclusively assigned to PACEdge. By default, this port is configured to use the DHCP protocol to receive a valid IP Address. Therefore, a DHCP server is needed to make first use of this port and to access Linux.

The GPOK LED, located on the front panel, indicates the status of the PACEdge interface. Steady Green indicates PACEdge running and ready for login.

Serial COM Port

The RJ45 port marked Serial COM is located on the underside of the CPL410/CPE400, as shown in Figure 2. Effective with firmware release 9.40, the CPL410/CPE400 supports the serial port. This port supports Serial IO protocol.

Video DisplayPort

The DisplayPort is located on the underside of the CPL410/CPE400, as shown in Figure 2. It provides signals for connecting either a suitable monitor or video adapter to the unit. **This port is not currently supported.**

Figure 2: Underside Ports & Connections

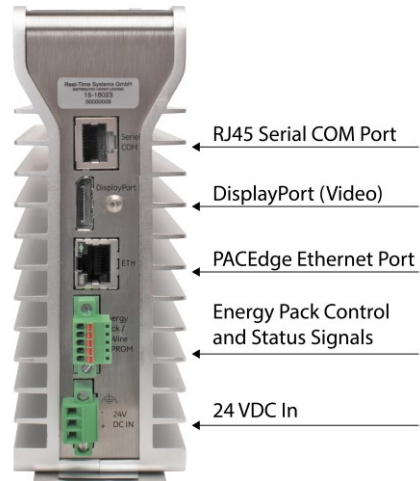

Energy Pack Connector

The CPL410/CPE400 compatible Energy Pack, IC695ACC403, is supplied with a purpose-built cable, IC695CBL003, which installs in the 24 VDC In and Energy Pack Control & Status connectors shown in Figure 2. Use of the Energy Pack is optional. When used, it allows the CPL410/CPE400 to save its current state upon loss of power. Refer to the *PACSystems RX3i Rackless Energy Pack IC695ACC403 Quick Start Guide*, GFK-3000, for complete wiring and grounding instructions.

Input Power Connector

If no Energy Pack is to be connected, refer to the *Connect to Power Supply* section. Otherwise, refer to the *PACSystems RX3i Rackless Energy Pack IC695ACC403 Quick Start Guide*, GFK-3000.

Removable Data Storage Device (RDSD)

The CPL410/CPE400 is equipped with a micro-SD card slot. **Currently not supported.**

Hardware Installation

Initial Checks

Upon receiving the equipment, carefully inspect all shipping containers for damage. If any part of the system is damaged, notify the carrier immediately. The damaged shipping container should be saved as evidence for inspection by the carrier.

As the consignee, it is the user's responsibility to register a claim with the carrier for damage incurred during shipment. Emerson will fully cooperate with the user, however, should such action be necessary.

After unpacking the equipment, record all serial numbers. Serial numbers are required if the user should need to contact Customer Care during the warranty

period. All shipping containers and all packing material should be saved should it be necessary to transport or ship any part of the system.

Verify that all components of the system have been received and that they agree with the order. If the system received does not agree with the customer's order, contact Customer Care.

Installation

For instructions on wall mounting instructions, DIN rail mounting instructions, or minimum clearances required, please consult GFK-2222, RX3i CPU Reference Manual.

As shipped, the CPL410/CPE400 is intended for mounting on a DIN rail. A panel-mount adaptor is also available. If panel-mounting is required, replace the DIN-rail adaptor with the panel-mount adaptor using the screws supplied with that adaptor. Both adaptors attach to the rear of the CPL410/CPE400 chassis using four Torx M3 screws. Torque newly-installed screws to 5.3 in-lbs (0.6 Nm) if installing a new adaptor plate. For installation to standards, refer to the Installation and Maintenance Requirements document, GFK-3004.

Installation in Hazardous Areas

Refer to *Installation and Maintenance Requirements*, GFK-3004.

Connect to Power Supply

The 24 VDC power input connector is located on the underside of the CPL410/CPE400, as shown in Figure 3. The signal pinouts are also indicated.

The mating connector for the CPL410/CPE400 24Vdc power input is the 3-pin Phoenix 1827716 shown in Figure 4. The power supply cable prepared by the user must use the specified mating connector.

The positive “+” and negative “-” signals are required. FGND is optional but recommended.

For the mating connector, the compatible conductor size is from 24AWG to 16AWG. Strip the wires back 7mm before inserting into the connector. Tightening torque for the three signal screws is 2.2 in-lbs (0.248Nm). Secure the mating connector to the power input connector via the two captive screws provided.

Figure 3: 24 VDC Power Input Connector



The user-supplied SELV² power supply must supply voltage in the range of 18Vdc to 30Vdc.

Once the power supply cable (or compatible Energy Pack ACC403) has been attached to the CPL410/CPE400 and the power supply has

² SELV = Safety Extra Low Voltage

been turned on, the unit will start booting. There is no need to push any button.

The unit is equipped with built-in reverse polarity protection. If + and - are swapped the unit will not power-up. If + is connected to FGND, this will cause a short. The power supply needs to protect itself against this condition.

Figure 4: 24 VDC Power Input Module Connector

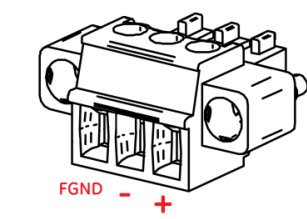

Inrush Current

The CPL410/CPE400 may experience an inrush current of up to 49 A for 15 μ s.

Overvoltage Protection

In the CPL410/CPE400, the voltage to the inner loads is clamped to 33 VDC. At 33 VDC, the internal clamping diode starts conducting at 1 mA. Any further increase in the voltage will cause the internal current fuse to blow and/or the clamping diode to break.

CAUTION

EQUIPMENT REPAIR REQUIRED – Internal components must be repaired at the factory; they are not field replaceable. Contact the support team at the link provided at the end of this document.

Overcurrent protection

The function protects the internal circuitry from overcurrent conditions before serious damage can occur, such as overheating of the equipment. The fuse is rated for 4 A continuous current. Once the sensed current reaches 40 A, the fuse will blow after a period of 10ms to 100ms.

Grounding

Grounding via the FGND connection on the 3-pin 24 VDC In power header is recommended (see the *Connect to Power Supply* section), but is not required if the CPL410/CPE400 is mounted to a grounded metal panel. Furthermore, if an Energy Pack is connected, be sure to comply with grounding procedures as described in *PACSystems RX3i Rackless Energy Pack IC695ACC403 Quick Start Guide*, GFK-3000.

Module Start-up Equipment Needed

- This PACSystems Rackless RX3i CPU.

- A compatible SELV 24Vdc, 48W power supply (72W if Energy Pack attached).
- (Optionally) A compatible Energy Pack, IC695ACC403, and corresponding cable.
- If no Energy Pack is to be attached, use the power supply cable described in section Connect to Power Supply. Otherwise, refer to PACSystems RX3i Rackless Energy Pack IC695ACC403 Quick Start Guide, GFK-3000.
- A DIN rail, typically mounted in an enclosure, as discussed above. Alternately, mount the unit using the compatible panel-mount adaptor.
- A computer running Web Browser to access PACEdge and PAC Machine Edition™ (PME) configuration and programming software. PME Version 9.70 SIM 16 or later supports the CPL410/CPE400. Version 9.50 SIM 5 is required for Hot Standby Redundancy.
- Ethernet cable for connecting the PME programmer computer to the CPL410/CPE400.
- Additional cables, as needed, to connect each port employed in the application.
- A very small, slotted screwdriver to secure the 24 Vdc mating connector.
- A T8 Torx screwdriver, if the micro-SD slot cover is to be removed. Note that the cover must be replaced to achieve immunity from electrical noise.
- A T10 Torx screwdriver, if exchanging the mounting adaptors.

Basic Start-up Steps

For startup and configuration of the CPL410/CPE400, complete the following steps. For full details on CPL410/CPE400 operation, refer to the *PACSystems RX3i and CPU Reference Manual*, GFK-2222Y or later.

- Mount the CPL410/CPE400, as described in the Installation section and per the Installation and Maintenance Requirements document, GFK-3004.
- Attach the user-supplied power supply cable as described in Connect to Power Supply if no Energy Pack is being used.
- (optionally) Mount and attach the compatible Energy Pack, IC695ACC403, as described in the PACSystems RX3i Rackless Energy Pack IC695ACC403 Quick Start Guide, GFK-3000.
- Turn on the power supply unit: the unit should then run without the need to press any buttons.
- If not previously configured, configure the RX3i PLC using PME 9.00 SIM 8 or later, as described in the CPL410/CPE400 PLC Configuration section below.
- Once GPOK LED is on, use web browser to connect to PACEdge software, see section PACEdge Quick Start for details.

Note: When the ACC403 Energy Pack is powered up, a finite period is required to charge it up to its operating level. During this time, the Energy Pack will indicate this condition via its LEDs (refer to the *PACSystems RX3i Rackless Energy Pack IC695ACC403 Quick Start Guide*, GFK-3000).

The CPL410/CPE400 will begin its boot cycle immediately upon power application. However, the embedded controller will not start its control until the ACC403 is charged. This typically takes 45 seconds or less. In the event the ACC403 is faulty or is not communicating, CPL410/CPE400 commences operation without the Energy Pack.

Note: In the event of loss of power, with the ACC403 Energy Pack connected and charged up, the CPL410/CPE400 remains on for 4 seconds to backup user memory into its non-volatile memory.

CPL410/CPE400 PLC Configuration

To configure, the CPL410/CPE400, connect the computer running the PME programming software to any of the front-panel LAN 1 or LAN 2 Ethernet ports. PME 9.00 SIM 8 or later is required

The CPL410/CPE400 is the first controller available in the *PACSystems RX3i Rackless* family. Configuration will either start out using the RX3i Rackless CPL410/CPE400 template when creating a new project or will convert an existing project to the CPL410/CPE400 using the *Family Conversion* feature in PME.

Backwards Compatibility

To convert an existing project which uses any other PLC, use the *Family Conversion* feature in PME. Be aware of the constraints involved, as will be notified in PME. For instance, the first PROFINET Controller in an RX3i CPU320 application will be assigned to the embedded PROFINET Controller feature of the CPL410/CPE400.

PROFINET Controller Configuration

An Embedded PROFINET Controller may be configured on LAN2. To enable the PROFINET Controller in a CPL410/CPE400 project, select the CPL410/CPE400 target in the *PME Navigator* (Figure 5) and open the Hardware Configuration. On the *Settings* tab, change the designated *LAN Mode* of the selected port to *PROFINET*. The *PROFINET Controller* node description then displays that a PROFINET node exists on the selected LAN (under the CPL410/CPE400). For further details, refer to the *PACSystems RX3i PROFINET IO Controller User Manual*, GFK-2571.

Figure 5: PME Navigator Showing PROFINET Node on LAN2

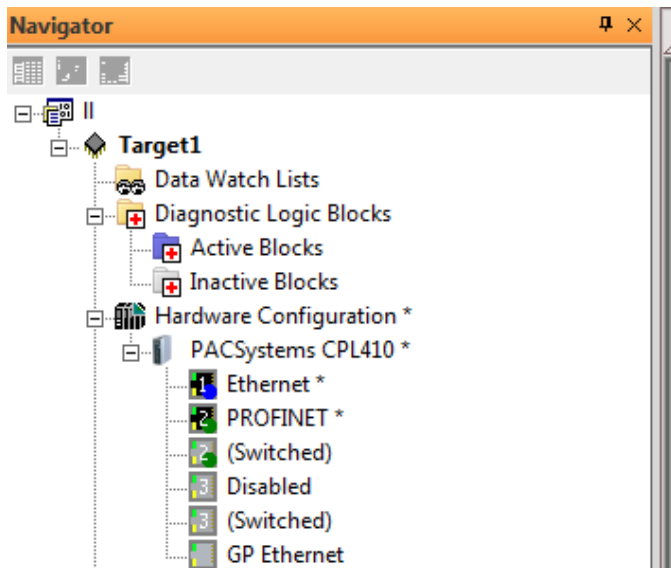

Redundancy Configuration

It is possible to configure the RX3i PLC part of CPL410/CPE400 as a Hot Standby Redundancy CPU with PROFINET IO. The two ports on LAN3 are used exclusively for this purpose: they provide a high-speed data synchronization link between the two CPUs. Connect the upper LAN3 port of the Primary CPU to the upper LAN3 port of the Secondary CPU and connect the lower LAN3 port of the Primary to the lower LAN3 port of the Secondary. Note that no additional hardware, other than the two redundant CPUs, may be connected to LAN3.

To enable redundancy in a CPL410/CPE400 project, select the CPL410/CPE400 target in the *PME Navigator* and use the *Property Inspector* to change the *Enable Redundancy* target property to *True*.

Important: Set the *Background Window Timer* to a minimum of 5ms in both the Primary and Backup CPL410/CPE400 hardware configurations. The *Background Window Timer* setting may be found on the *Scan* Tab in the CPL410/CPE400's hardware configuration.

Once configured for HSB Redundancy, the RACT and RBOK LEDs (Figure 1) become functional. RACT indicates the Local CPU is Ready & Active; RBOK indicates the Remote CPU is Ready. These two LEDs are also reflected in the Status Data of the CPU and are presented as OPC UA Variables.

The OLED display includes two menu items used in conjunction with Redundancy:

- RDN Info provides status information via the OLED display.
- RDN Command permits the operator to perform a Role Switch.
- For further details, refer to the *PACSystems Hot Standby CPU Redundancy User Manual*, GFK-2308 (rev L or later).

PACEdge

PACEdge +Connext

The CPE400 with PACEdge +Connext OPC UA provides data collection and management software for high data demand applications. The Connext software features an OPC UA Server that has been designed to provide companies with seamless and effortless connectivity towards different types of field devices in the automation, infrastructure and process control sectors.

Note: Customers that have a previous model of the CPE400 without the PACEdge + Connect are able to download and license the software from the MAS Customer Portal free of charge.

PACEdge +WebHMI

The CPL410 with PACEdge +WebHMI UA provides HMI visualization combined with best-in-class data collection and management. The bundled WebHMI provides HMI/SCADA and productivity tools, which will in turn improve up-time.

Note: Customers that have a previous model of the CPL410 without the PACEdge+Connex are able to download and license the software from the MAS Customer Portal free of charge.

<https://emerson-mas.force.com/communities/>

PACEdge Quick Start

CPL410/CPE400 units come with pre-installed PACEdge software. Following chapters will describe how to get started with PACEdge.

For more details, please reference a the PACEdge User Manual (GFK-3178).

PACEdge Usage Model

PACEdge software on CPL410/CPE400 is designed to be used in a headless mode, with the user accessing it remotely via Ethernet using a web browser.

Figure 6: Use Case

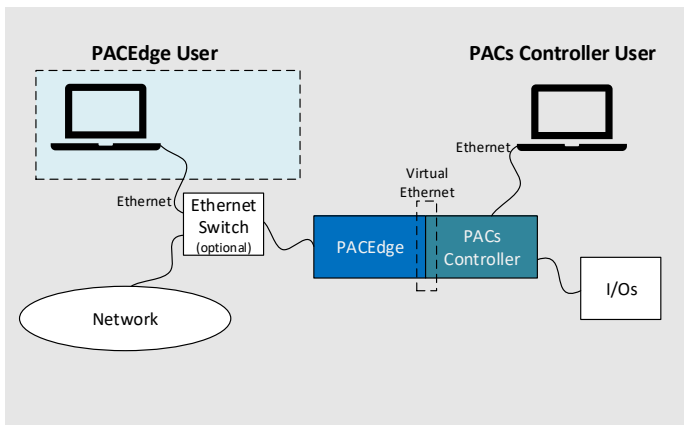

Getting Started

1. Connect the Ethernet cable to the Ethernet port on the bottom of the unit, labeled ETH.
2. Setup the User PC Ethernet port IP address to be statically assigned as follows:
 - a. **IPv4 Static IP: 192.168.3.10**
(or similar in the same subnet)
 - b. **Netmask: 255.255.255.0**
3. Power up the unit and wait until GPOK LED is solid green. (Steady green indicates that PACEdge is running and ready for login.)
4. Open the browser of your choice and type in **192.168.3.100** or, if known, **hostname.local**, in the address bar. The **hostname** is **pacedge-xxxxxx**, where xxxxxx are the last 6-digits of the Ethernet MAC address. For instance, if the last six digit of the MAC address are **e3c2d9**, then unit can be accessed by entering: **pacedge-e3c2d9.local**

Note: Ethernet port is also configured to get IP addresses assigned by the DHCP server. This dynamically assigned IP address can also be used to access PACEdge. The user can locate the IP address assigned by DHCP server by using LCD display and navigating to Edge Settings - > Network Config section.

Initial Login

When the user connects to PACEdge for the first time, a warning message will display due to the self-signed certificate on the unit. The message will state that the identity of the device could not be confirmed. Please click on **Advanced** and **Accept** to proceed.

Note: Please consult the PACEdge User Manual, Security Certificate Management section for details on how to setup the PKI and access PACEdge using the hostname instead of the IP address

Please read and accept the Emerson End User License Agreement (EULA).

Once EULA has been accepted you will be redirected to the Password Management screen. PACEdge software consists of multiple software tools and applications, each having its user management and password settings. To simplify this task, PACEdge comes with pre-configured users: *admin*, *developer*, *service* and *operators*, each having its own password. Use the Password Management screen to change passwords in two steps: 1) for all PACEdge Applications, 2) for Cockpit/Linux. (Figure 7). When changing the passwords, follow instructions on the screen and consult help information accessible via question mark button in the upper right corner.

Note: For both, cybersecurity reasons, and for proper user account setup, the user must change the default passwords at the first login. **Important:** Please consult the PACEdge Secure Deployment Guide (GFK-3197) for recommended password changes and other cybersecurity-relevant settings.

Figure 7: Password Management Screen (top portion: PACEdge Applications, bottom portion: Cockpit/Linux)

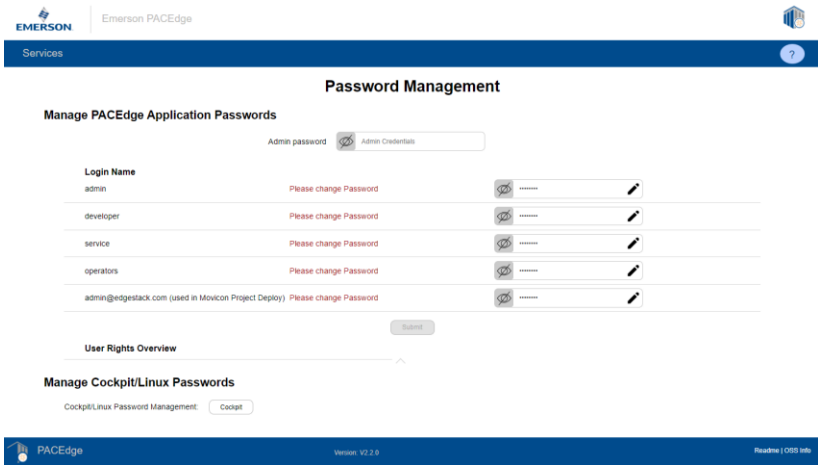

Once the passwords have been changed, click on the Emerson logo in the upper-left corner. The logo is a shortcut to the PACEdge Landing Page, which has further shortcuts to Node-RED, Grafana, Cockpit, Portainer, and other applications. The user can return to the Password Management screen from the PACEdge landing page by clicking **Password Management** in the Settings drop-down list on the right side.

Figure 8: PACEdge Landing Page

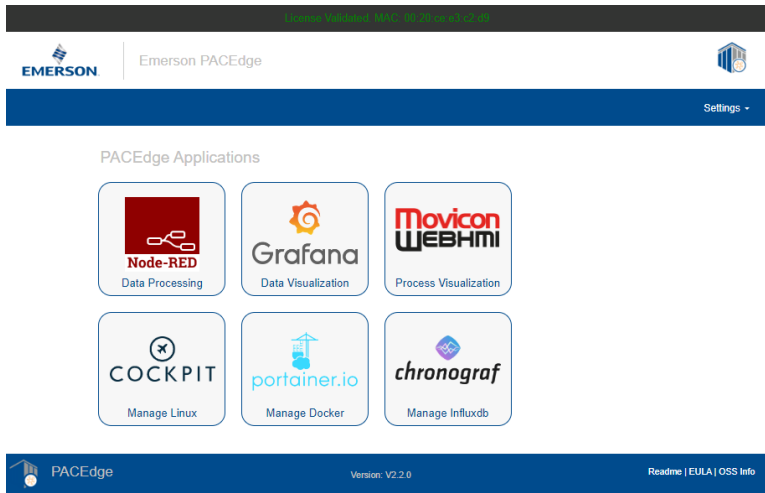

To explore PACEdge, click on Node-RED and log in with:

- **user:** admin
- **password:** edgestack (or the password that was set on the Password Services page)

Start exploring example flows or create your own flows. Consult the PACEdge User Manual (GFK-3178) for example details.

Important: Please consult the PACEdge Secure Deployment Guide (GFK-3197) for recommended password changes and other cybersecurity relevant settings.

Factory Reset

In the event that a user locks themselves out of PACEdge, or PACEdge fails to start following a misconfiguration, PACEdge can be restored to its original manufacturer settings:

- Factory Reset can be triggered via the OLED-Display Menu: Edge Settings->Commands->Factory Reset.
- After the Factory Reset has been triggered, a manual power cycle must be executed.

Important: Emerson recommends disconnecting the power to the PLC instead of using the power button. Using the power button may result in the loss of User Memory in RAM.

Note: Please ensure the PLC and controlled facilities are in a secure state when cycling power. Placing the PLC in Stop mode is recommended.

- When CPL410/CPE400 boots up again, PACEdge disc partitions will be overwritten with default data. The LED GPOK is off during reset and will turn solid green when reset is finished.

Note: All PACEdge data, user modifications, updates, database content will be deleted during the factory reset process. Therefore, consider making backups of all databases and changes applied to PACEdge frequently.

Additional Information

<i>PAC Logic Developer-PLC Getting Started</i>	GFK-1918
<i>PACSystems RX3i and RSTi-EP CPU Reference Manual</i>	GFK-2222
<i>PACSystems RX3i and RSTi-EP TCP/IP Ethernet Communications User's Manual</i>	GFK-2224
<i>PACSystems TCP/IP Ethernet Communications Station Manager Manual</i>	GFK-2225
<i>PACSystems Hot Standby CPU Redundancy User Manual</i>	GFK-2308
<i>PACSystems RX3i System Manual</i>	GFK-2314
<i>PACSystems RXi, RX3i and RSTi-EP Controller Secure Deployment Guide</i>	GFK-2830
<i>PACSystems RX3i and RSTi-EP CPU Programmer's Reference Manual</i>	GFK-2950
<i>PACSystems HART[®] Pass Through User Manual</i>	GFK-2929
<i>PACSystems RX3i PROFINET IO Controller User Manual</i>	GFK-2571
<i>PROFINET I/O Devices Secure Deployment Guide</i>	GFK-2904
<i>PACSystems RX3i Rackless Energy Pack IC695ACC403 Quick Start Guide</i>	GFK-3000
<i>PACSystems RX3i IC695CPE400 and IC695CPL410</i>	GFK-3003
<i>Important Product Information</i>	
<i>PACEdge Important Product Information</i>	GFK-3198
<i>PACEdge User Manual</i>	GFK-3178
<i>PACSystems DNP3 Outstation User Manual</i>	GFK-3103

Contact Information and Support

Questions? We are here to help.

Search our Knowledge Base	Open a Support Ticket	Register for a Customer Account
 pacsystems.co/ knowledge	 pacsystems.co/support	 pacsystems.co/ signup
Customer Center Home Page	Commercial Website	Contact Information
 pacsystems.co/ customercenter	 pacsystems.co/ commercial	 pacsystems.co/ contactus

