

# PACSystems™ RX3i

NON-ISOLATED ANALOGUE OUTPUT MODULE  
WITH HART COMMUNICATION (IC695ALG728)

NON-ISOLATED ANALOGUE OUTPUT MODULE  
(IC695ALG704 & IC695ALG708)

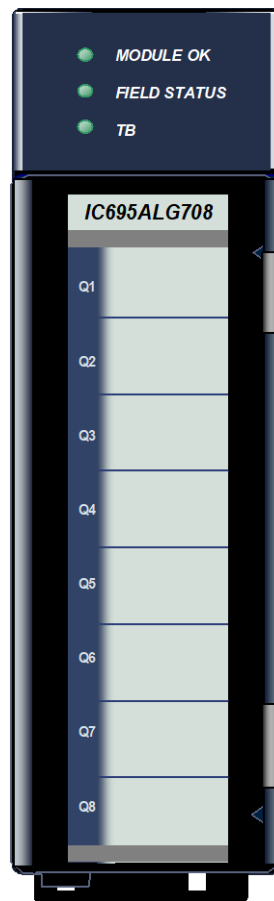

## Product Description

**Non-Isolated Analog Voltage/Current Output** module IC695ALG704 provides four configurable voltage or current output channels.

**Non-Isolated Analog Voltage/Current Output** module IC695ALG708, shown at left, and **Non-Isolated Analog Voltage/Current Output** module IC695ALG728 both provide eight configurable voltage or current output channels. Module IC695ALG728 also features HART version 5.0 communications capability on each channel.

Analog channels can be configured for these output ranges:

- Current: 0 to 20mA, 4 to 20mA
- Voltage: +/- 10V, 0 to 10V

On module IC695ALG728, channels that will use HART communications must be configured for the 4-20mA range.

These modules must be located in an RX3i Universal Backplane. Modules IC695ALG704 and IC695ALG708 require an RX3i CPU with firmware version 3.0 or later. Module IC695ALG728 requires an RX3i CPU with firmware version 3.5 or later. PAC Machine Edition Version 5.0 SP3 Logic Developer-PLC or later must be used for configuration.

These modules can be used with a Box-style (IC694TBB032), Extended Box-style (IC694TBB132), Spring-style (IC694TBS032), or Extended Spring-style (IC694TBS132) Terminal Block. Extended terminal blocks provide the extra shroud depth needed for shielded wiring. See the PACSystems RX3i System Manual, GFK-2314 revision B or later for more information about Terminal Blocks. Terminal Blocks are ordered separately.

## Isolated +24 VDC Power

The module must receive 24 VDC field power from an external source. The external source must be connected directly to the module's terminal block. It cannot be connected via the TB1 connector on the RX3i Universal Backplane.

## Module Features

- Completely software-configurable, no module jumpers to set
- Individually enable or disable channels
- Clamping and Alarm Limits
- Latching of Alarms
- Configurable output bias
- Rapid channel acquisition times based on filter frequency
- Full autocalibration
- On-board error-checking
- Configurable scaling and offsets per channel
- High alarm, low alarm, high-high alarm, low-low alarm detection and reporting selectable per channel
- Module fault reporting
- Configurable Hold Last State or Output Defaults
- Version 5.0 HART communications supported on module IC695ALG728.

## Release History

Module Version	Firmware Revision	Upgrade Kit	Comments
IC695ALG704-ED IC695ALG704CA-ED IC695ALG708-ED IC695ALG708CA-ED IC695ALG708LT-ED IC695ALG728-ED IC695ALG728CA-ED	2.01	None	Document changes to address error regarding firmware upgrades. No firmware upgrades are available.
IC695ALG704-ED IC695ALG704CA-ED IC695ALG708-ED IC695ALG708CA-ED IC695ALG708LT-ED IC695ALG728-ED IC695ALG728CA-ED	2.01	None	This change addresses component obsolescence with new FW to support a drop-in replacement serial flash device. There are no changes to form, fit, or function.
IC695ALG704-EC IC695ALG704CA-EC IC695ALG708-EC IC695ALG708CA-EC IC695ALG708LT-EC IC695ALG728-EC IC695ALG728CA-EC	2.00	None	Following Emerson's acquisition of this product, changes have been made to apply appropriate branding and registration of the product with required certification agencies. No changes to material, process, form, fit or functionality.
IC695ALG704-DC IC695ALG704CA-DC IC695ALG708-DC IC695ALG708CA-DC IC695ALG708LT-DC IC695ALG728-DC IC695ALG728CA-DC	2.00	None	HW/FW change to address obsolescence and implement EU RoHS compliance 2011/65/EU  CA = Conformal Coated version LT = Low Temperature version
IC695ALG704-CB IC695ALG708-CB	1.08	44A753281-G01 44A753282-G01	Label change only. No change in functionality, performance or compatibility.
IC695ALG704-BB IC695ALG708-BB	1.08	44A753281-G01 44A753282-G01	Modified the terminal block detector switch to increase the size of the switch lever. The increased size of the switch lever allows additional tolerance to assure contact with the terminal block actuator.
IC695ALG728-AB	1.01	44A753283-G01	
IC695ALG704-AA IC695ALG708-AA	1.06	None	Initial Release
IC695ALG728-AA	1.00	None	Initial Release

## Firmware Upgrade

Previous module versions **cannot** be upgraded to FW release version 2.00 or later and must use their associated FW versions listed in the table above.

# Functional Compatibility

## ALG704/708 Functional Compatibility

Subject	Description
Programmer Version Requirements	PAC Machine Edition Logic Developer 5.0 + Service Pack 3 or later must be used to configure and program the Non-Isolated Analog Modules.
CPU Firmware Version Requirements	The PACSystems RX3i CPU version 3.0 or later must be used to configure and operate the Non-Isolated Analog Modules.

## ALG728 Functional Compatibility

Subject	Description
Programmer Version Requirements	PAC Machine Edition Logic Developer 5.5 or later must be used to configure and program the Non-Isolated Analog Modules with HART.
CPU Firmware Version Requirements	The PACSystems RX3i CPU version 3.50 or later must be used to configure and operate the Non-Isolated Analog Modules with HART.

## Problems Resolved in this Release

None

## New Features and Enhancements

FW change to address serial Flash component obsolescence.

## Known Restrictions and Open Issues for Modules IC695ALG704 & IC695ALG708

Problem: Using a SVC\_REQ 24 to reset an ALG704 or ALG708 module causes the module to lose its configuration and become inoperable. Recommendations: To restore the configuration and resume module operation, reset or power cycle the module.

To prevent problems, use SVC\_REQ 24 only as a one-shot and wait at least 5 seconds between re-execution of a SVC\_REQ 24 reset request to the same module.

## Operating Notes

These modules have separate enable/disable options for Diagnostic Reporting and Interrupts. Normally, disabling a diagnostic (such as Low/High Alarm or Over/Under range) in the configuration means that its diagnostic bit is never set. However, if interrupts are enabled for a condition and that interrupt occurs, the diagnostic bit for that condition is also set during the same PLC scan. The next PLC input scan always clears this interrupt status bit back to 0, because Diagnostic Reporting has it disabled.

When using Winloader to update the firmware on module IC695ALG728, field power must be present. The module's HART daughterboard is powered by field power and also has flash memory that is updated during the firmware update process. Thus, to successfully update the HART daughterboard flash, field power must be present.

## Specifications

Specification	Description
Output Ranges	Current: 0 to 20mA, 4 to 20mA Voltage: +/- 10V, 0 to 10V
Backplane Power Requirements	IC695ALG704: 250 mA maximum at 3.3V IC695ALG708: 250 mA maximum at 3.3V IC605ALG728 with HART enabled: 250mA maximum at 3.3V
Power Dissipation within Module	IC695ALG704: 4.8 Watts maximum (Vuser=24V) IC695ALG708, IC695ALG728: 7.25 Watts maximum (Vuser=24V)
Thermal Derating	IC695ALG704: no derating. IC695ALG708, see derating curves later in this document IC695ALG728: please refer to the RX3i System Manual, GFK-2314C or later for derating information.
External +Power Supply	Voltage Range: 19.2V to 30V (24V nominal) Current required for ALG704: 150 mA maximum Current required for ALG708: 250 mA maximum Current required for ALG728: 250 mA maximum
Resolution	+/-10V: 15.9 bits, 0 to 10V: 14.9 bits, 0 to 20mA: 15.9 bits, 4 to 20mA : 15.6 bits
HART Communications	Version 5.0 HART protocol supported on module IC695ALG728.
Output Data Format	Configurable as floating point IEEE 32 bit or 16-bit integer in a 32-bit field
Analog Update Rate (Determined by I/O scan time, application dependent)	IC695ALG704 and ALG708: 8 milliseconds (approximate, all eight channels) ALG728: 16mS with HART (approximate, all eight channels) 8mS without HART (approximate, all eight channels)
<p>HART Data Scan Time (in seconds) The HART data scan can consist of up to four acquisition cycles (similar but asynchronous to the analog scan time). Each cycle includes a specific set of channels. Total HART scan time depends on the number of channels enabled for HART within a specific set of channels, number of retries, enabling/disabling of slot variables, and use and configuration settings of pass-thru commands.</p>	
One HART Channel in Group	Each HART Data channel updates every 0.7 second (typical)
Two HART Channels in Group	Each HART Data channel updates every 1.9 seconds (typical)
Three HART Channels in Group	Each HART Data channel updates every 3.0 seconds (typical)
Four HART Channels in Group	Each HART Data channel updates every 4.0 seconds (typical)
Output Overvoltage Protection	Current outputs only: -30V for 60 seconds, +30V for one hour
Calibrated Accuracy	Accurate to within 0.15% of full scale at 25°C Accurate to within 0.25% of full scale at 60°C In the presence of severe RF interference (IC 801-3, 10V/M), accuracy may be degraded to +/-1% FS.
Output Load Reactance	Current: 10μH maximum, Voltage: 1μF maximum
Maximum Output Load	Current: 850 Ohms maximum at Vuser = 20V Voltage: 2 Kohms minimum
Output Gain Drift	Voltage output: 20ppm per degree C typical Current output: 35ppm per degree C typical
Output Settling Time	ALG704, ALG708: Voltage or current output: 2ms, 0 to 95% ALG728: Voltage Output: 2ms, 0 to 95% Current output with HART: 70mS, 0 to 95% Current output without HART: 23ms, 0 to 95%
Isolation, Field to Backplane	2550VDC for one second
Maximum Compliance Voltage	Vuser – 3V (minimum) to Vuser (maximum)

Module IC695ALG704 has no thermal derating. Thermal deratings for modules IC695ALG708 and IC695ALG728 are shown below. Please refer to the *RX3i System Manual*, GFK-2314K or later for, for details.

## Output Points Vs Temperature, Current Mode

Figure 1: Thermal Derating for ALG708 in Current Mode

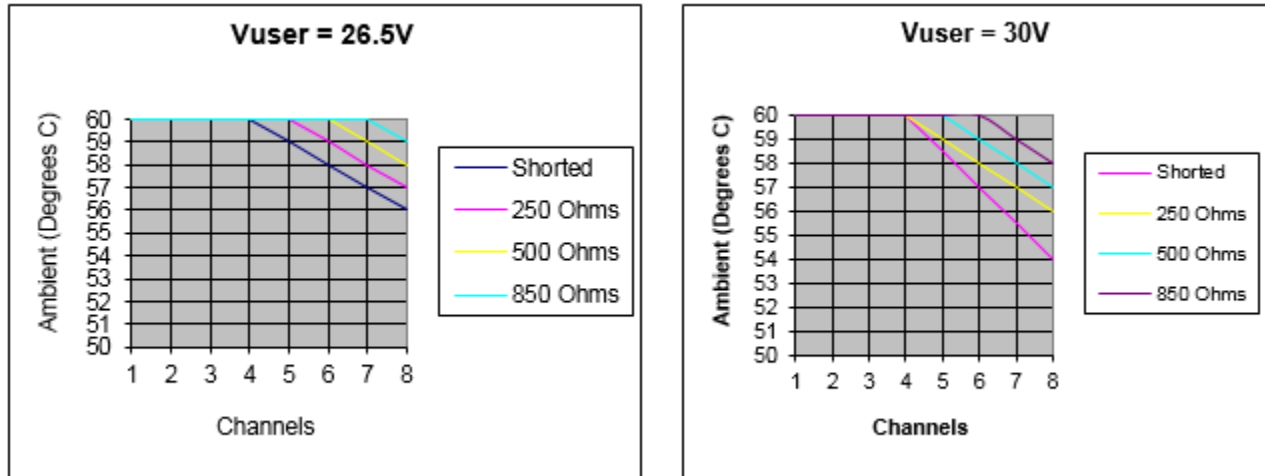
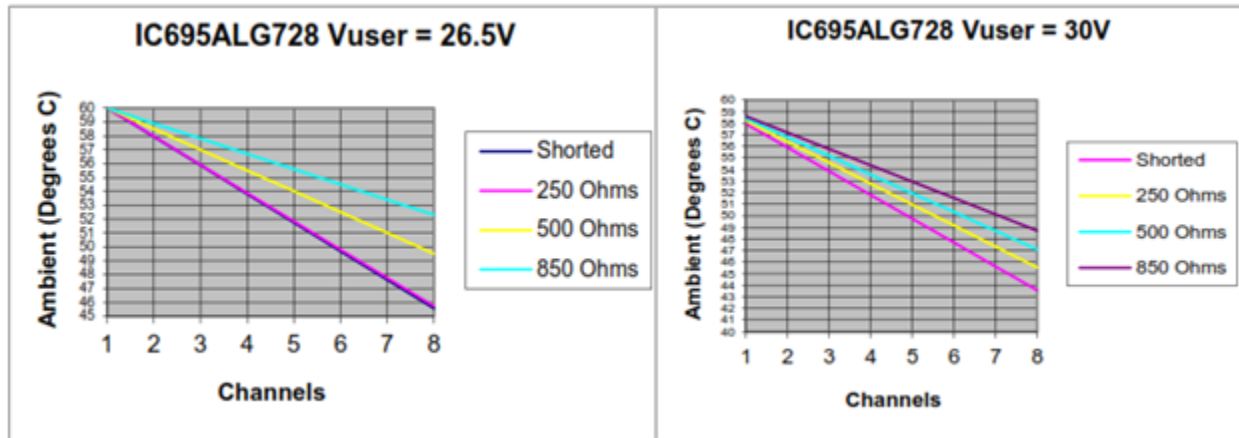

Figure 2: Thermal Derating Charts ALG728 in Current Mode



## LED Status

The **Module OK** LED indicates module status. The **Field Status** LED indicates whether the external +24 VDC power supply is present and is above the minimum level and whether or not faults are present. All LEDs are powered from the backplane power bus.

LED	Indicates
Module OK	ON Green: Module OK and configured. Quick Flashing Green: Module performing powerup sequence. Slow Flashing Green or Amber: Module OK but not configured. OFF: Module is defective or no backplane power present
Field Status	ON Green No faults on any enabled channel, Terminal Block is present, and field power is present. ON Amber and TB Green: Terminal Block is installed, fault on at least one channel, or field power is not present. ON Amber and TB Red: Terminal Block not fully removed, field power still detected. OFF and TB Red: Terminal block not present and no field power is detected.

## Field Wiring [XE “ Field Wiring : ALG616]

The table below lists wiring connections for the Non-Isolated Analog Output Modules. There are no shield terminals.

Terminal	4 Channel Modules	8 Channel Modules	4 Channel Modules	8 Channel Modules	Terminal
1	Channel 2 Voltage Out		Channel 1 Voltage Out		19
2	Channel 2 Current Out		Channel 1 Current Out		20
3	Common (COM)		Common (COM)		21
4	Channel 4 Voltage Out		Channel 3 Voltage Out		22
5	Channel 4 Current Out		Channel 3 Current Out		23
6	Common (COM)		Common (COM)		24
7	No Connection	Channel 6 Voltage Out	No Connection	Channel 5 Voltage Out	25
8	No Connection	Channel 6 Current Out	No Connection	Channel 5 Current Out	26
9	Common (COM)		Common (COM)		27
10	No Connection	Channel 8 Voltage Out	No Connection	Channel 7 Voltage Out	28
11	No Connection	Channel 8 Current Out	No Connection	Channel 7 Current Out	29
12	Common (COM)		Common (COM)		30
13	Common (COM)		Common (COM)		31
14	Common (COM)		Common (COM)		32
15	Common (COM)		Common (COM)		33
16	Common (COM)		Common (COM)		34
17	Common (COM)		Common (COM)		35
18	Common (COM)		External + Power Supply (+24V In)		36

Each channel can be individually configured to operate as a voltage output or a current output - not both simultaneously. All the common terminals are connected together internally, so any common terminal can be used for the negative lead of the external power supply.

**Figure 3: Field Wiring**

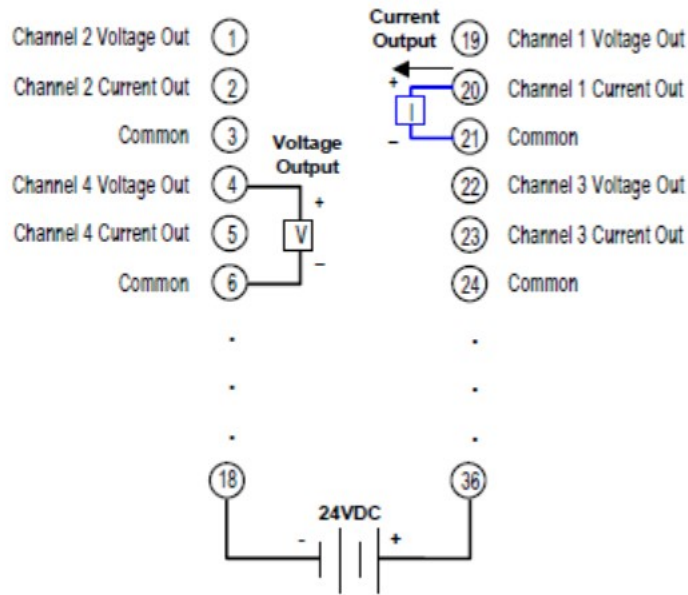

There are no shield terminals on these modules. For shielding, tie cable shields to the ground bar along the bottom of the backplane. M3 tapped holes are provided in the ground bar for this purpose.



# General Contact Information

Home link: <http://www.emerson.com/industrial-automation-controls>

Knowledge Base: <https://www.emerson.com/industrial-automation-controls/support>

## Technical Support

### Americas

Phone: 1-888-565-4155  
1-434-214-8532 (If toll free option is unavailable)

Customer Care (Quotes/Orders>Returns): [customercare.mas@emerson.com](mailto:customercare.mas@emerson.com)  
Technical Support: [support.mas@emerson.com](mailto:support.mas@emerson.com)

### Europe

Phone: +800-4444-8001  
+420-225-379-328 (If toll free option is unavailable)  
+39-0362-228-5555 (from Italy - if toll-free 800 option is unavailable or dialing from a mobile telephone)

Customer Care (Quotes/Orders>Returns): [customercare.emea.mas@emerson.com](mailto:customercare.emea.mas@emerson.com)  
Technical Support: [support.mas.emea@emerson.com](mailto:support.mas.emea@emerson.com)

### Asia

Phone: +86-400-842-8599  
+65-6955-9413 (All other Countries)

Customer Care (Quotes/Orders>Returns): [customercare.cn.mas@emerson.com](mailto:customercare.cn.mas@emerson.com)  
Technical Support: [support.mas.apac@emerson.com](mailto:support.mas.apac@emerson.com)

Any escalation request should be sent to: [mas.sfdcescalation@emerson.com](mailto:mas.sfdcescalation@emerson.com)

**Note:** If the product is purchased through an Authorized Channel Partner, please contact the seller directly for any support.

Emerson reserves the right to modify or improve the designs or specifications of the products mentioned in this manual at any time without notice. Emerson does not assume responsibility for the selection, use or maintenance of any product. Responsibility for proper selection, use and maintenance of any Emerson product remains solely with the purchaser.

© 2021 Emerson. All rights reserved.

Emerson Terms and Conditions of Sale are available upon request. The Emerson logo is a trademark and service mark of Emerson Electric Co. All other marks are the property of their respective owners.

