

IMPORTANT PRODUCT INFORMATION

READ THIS INFORMATION FIRST

Products: Adapter Kit for 8" QuickPanel* Units

IC754ACC08ADP-A

The UL Markings, ATEX Marking and all environmental ratings (NEMA4, UL50 Type 4X, and IP66) *have not been validated* for the 8" QuickPanel product when it is used with the 8" Adapter. Therefore, these agency compliances and standards do not apply to an 8" QuickPanel with the 8" Adapter installed.

Note: Use of a correctly installed Adapter does not affect the QuickPanel product's compliance with CE Marking and IP20 ingress protection level.

The 8" QuickPanel Adapter Kit allows you to mount an 8" QuickPanel into a panel that has a cutout for a 9" unit.

As per details below, the Adapter is first fitted into the 9" cutout provided on the customer panel. Then the 8" QuickPanel assembly should be inserted and clamped from back side of the customer panel.

Functional Compatibility

This adapter kit can be used with the following 8" QuickPanel models.

IC754CBF08CTD	Control Fully Loaded TFT
IC754CGF08CTD	Control Fully Loaded TFT
IC754CKF08CTD	Starter Kit, Control Fully Loaded TFT
IC754OBF08CTD	DisplayPAC-XScale Loaded Color TFT
IC754VBF08CTD	View Loaded Color TFT Touch DC
IC754VBI08CTD	View Intermediate Color TFT Touch DC
IC754VGF08CTD	View Loaded Color TFT Touch DC
IC754VGF08CTD IC754VGF08ABD	View Fully Loaded Color with DH+
IC754VGI08CTD	View Intermediate Color TFT Touch DC
IC754VGI08CTD IC754VGI08ABD	View Intermediate Color with DH+
IC754VKF08CTD	Starter Kit, View Fully Loaded TFT
IC754VKI08CTD	Starter Kit, View Intermediate TFT 24VDC

* indicates a trademark of GE Intelligent Platforms, Inc. and/or its affiliates. All other trademarks are the property of their respective owners.

Contents of Adapter Kit

Component	Part Number	Quantity
Plastic Adapter (with Gasket # 42G9319-0021-001R01)	42G9010-0012-001R01	1
Mounting Clamps (pack of 6)	42G9110-0005G02R01	1

Basic Elements of the Adapter Kit and Quick Panel Assembly

The following figure shows the QuickPanel Assembly and Adapter Kit installed into the customer panel.

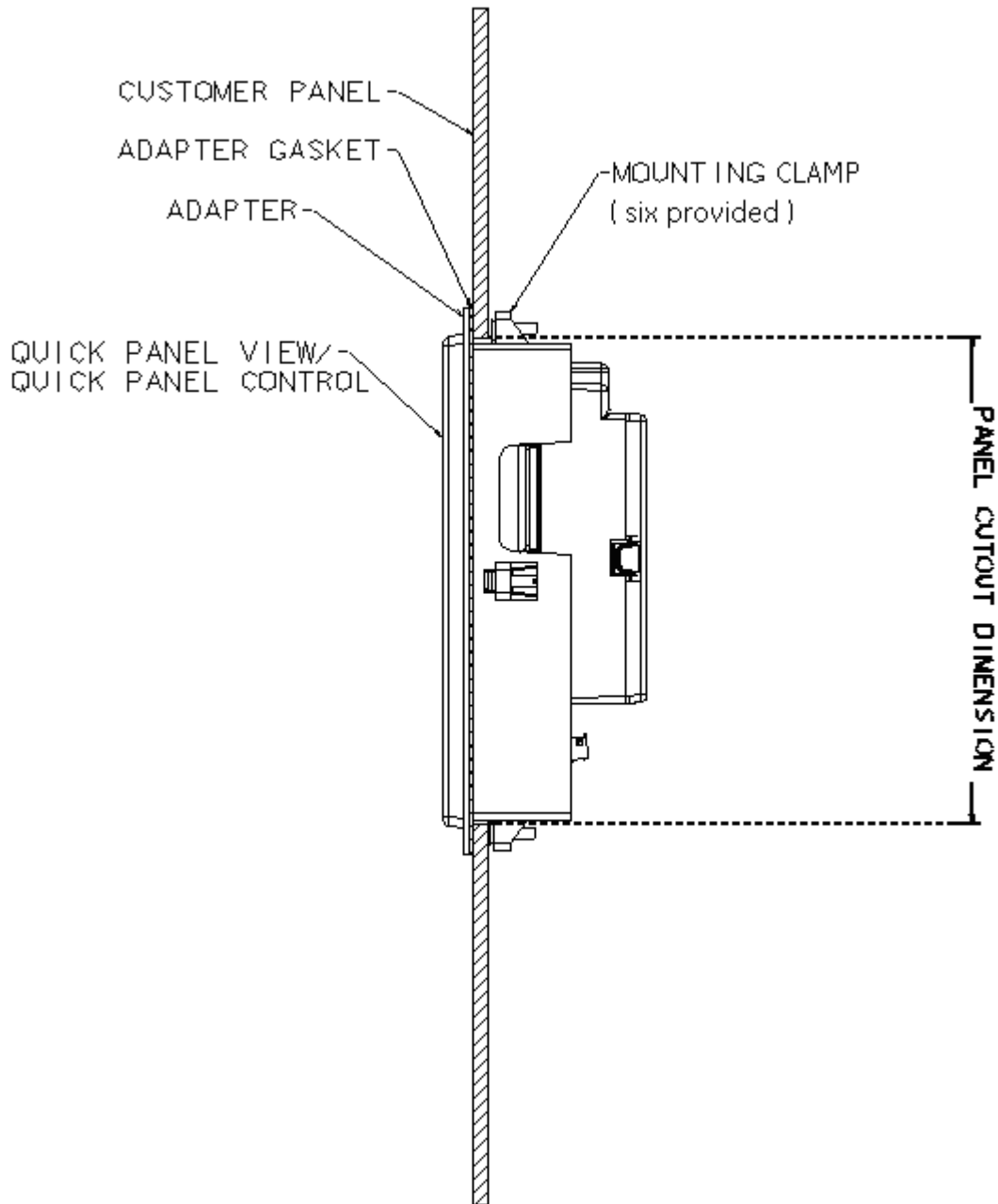

Side View of Adapter Kit and QuickPanel Assembly in the Customer Panel

GFK-2587A

Panel Cutout

The 8" QuickPanel Assembly with Adapter Kit requires the following cutout dimensions:

Width: 10.197 inches

Height: 7.913 inches

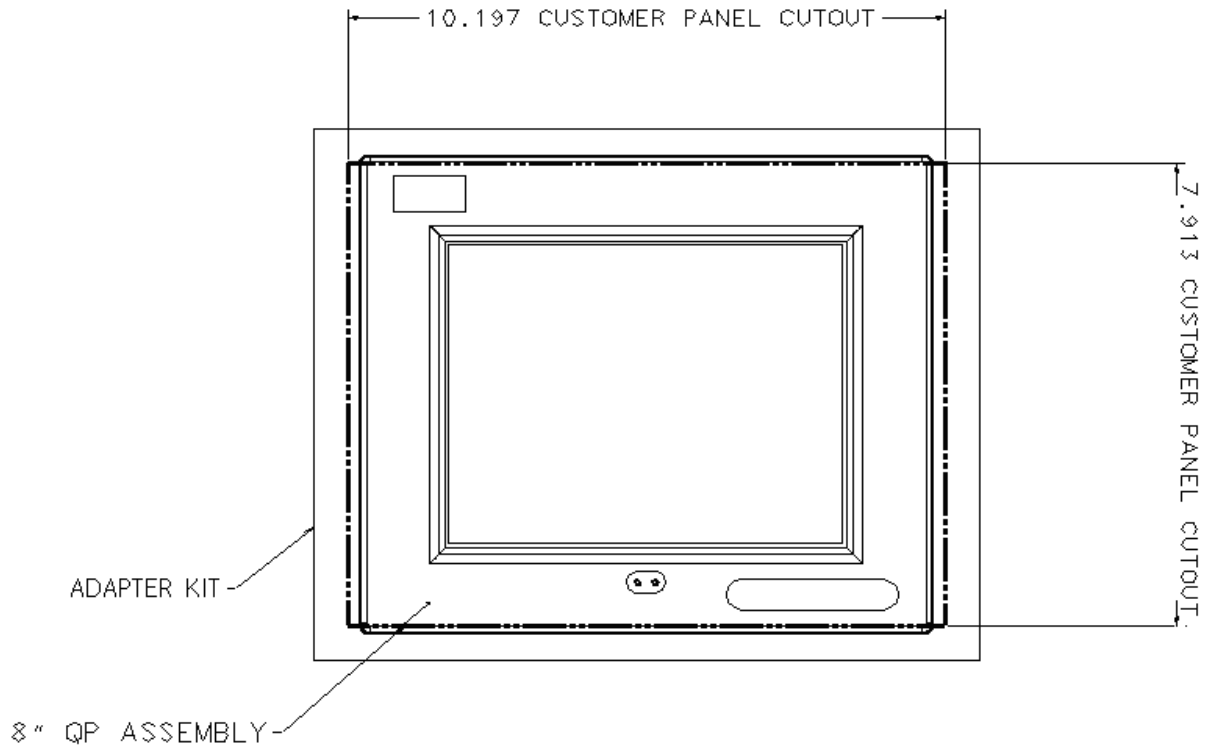

Installation Procedure

Notes:

- The unit will not fit through the cutout with a compact flash (CF) card inserted in the port.
 - The unit may not fit through the cutout with some cables attached, depending on the cable's hood design.
1. If there is a CF card in the QuickPanel's CF port, remove it. Remove any cables that may interfere with installation.
 2. Insert the Adapter assembly into the panel cutout as shown in the figure on the next page.
 3. Verify that adapter flange back face is completely sitting onto the panel face all the sides with no gap.

- Verify that the bezel gasket is properly seated in the bezel channel, then insert the QuickPanel assembly into the Adapter assembly as shown in the following figure.

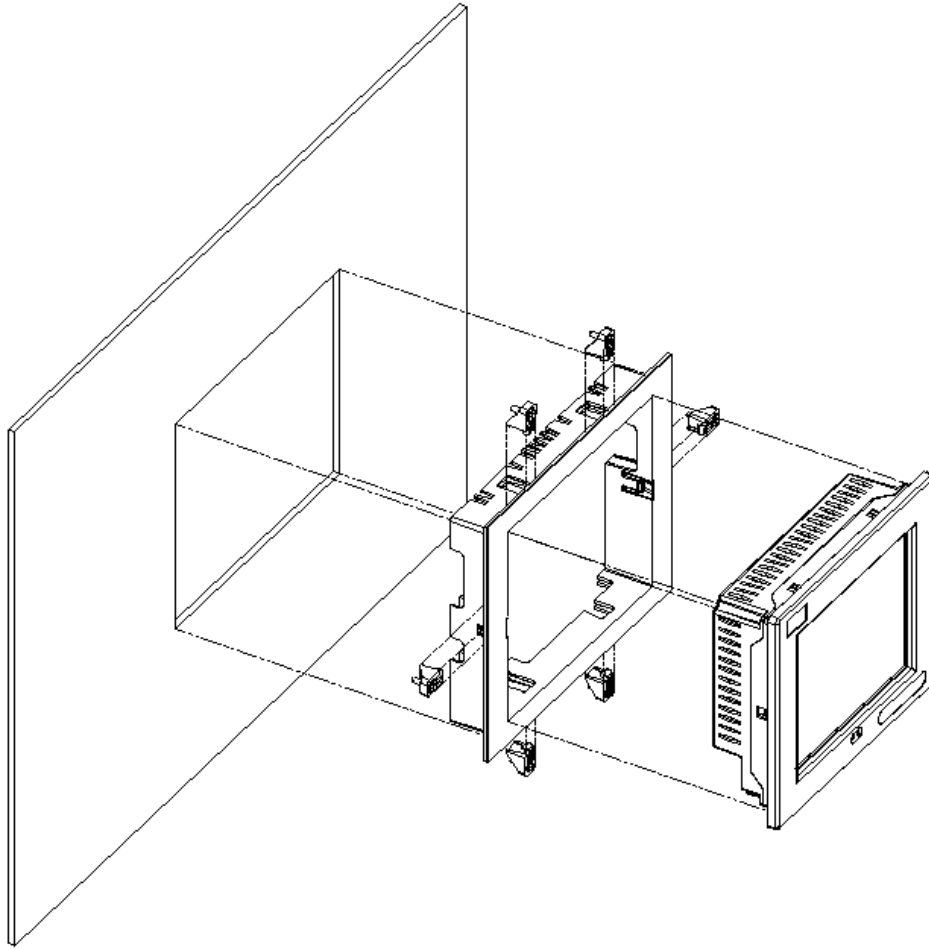

- Use the six included mounting clamps to secure the Adapter and QuickPanel to the panel. The clamps hook into openings located on the top, bottom, and sides of the housing as shown.
 - Insert the hook of each mounting clamp into the housing openings as shown in the figures on the next page.
 - Tighten the clamp screws within the torque range of 2.6–4.4 inch/lbs (0.3–0.5 Nm). Screws should be tightened to apply a uniform pressure of the QuickPanel to the gasket surface.
- Connect any cables that were removed in step 1. If a CF card was removed, install it in the CF port.

The mounting clamps hold the unit in place by tension. No drilling is required.

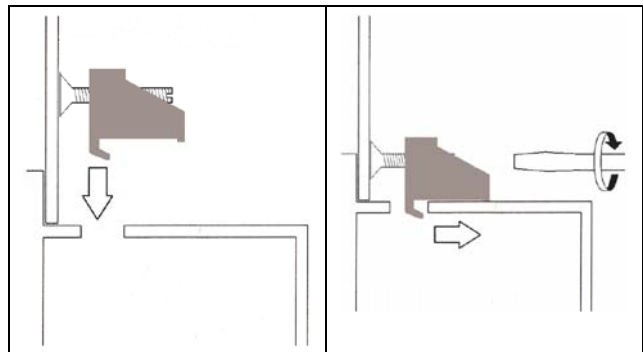

GFK-2587A

Mounting Clamp Locations

