

GE
Intelligent Platforms

Programmable Control Products

PACSystems* RX3i
IEC 61850 Ethernet Communication Module,
IC695ECM850

Quick Start Guide, GFK-2851
February 2014



Contents

1. User Features	3
1.1. Overview.....	3
1.2. Ethernet Ports.....	4
1.3. Micro USB Port	6
1.4. Restart Pushbutton	6
1.5. Light-Emitting Diode Indicators (LEDs).....	6
2. Hardware Installation.....	10
2.1. Initial Checks.....	10
2.2. Installation Location	10
2.3. Installation in Hazardous Areas.....	11
2.4. Module Installation	12
2.5. Ethernet Port Connections to IEC 61850 LAN.....	14
3. Configuration.....	18
3.1. Confirm ECM850 Communication with the CPU.....	18
3.2. Next Steps	19
4. Status and Diagnostic Data.....	21
4.1. Module Status Data (32 bits).....	21
4.2. Problems during Powerup and Reset.....	22
5. Additional Information.....	23
5.1. PACSystems RX3i User Manuals	23
5.2. Information about IEC 61850.....	23

1. User Features

1.1. Overview

The PACSystems RX3i IEC 61850 Ethernet Communication Module, catalog number IC695ECM850, or **ECM850**, connects a PACSystems RX3i controller to an IEC 61850 network, enabling the controller to act as an IEC 61850 Client and communicate with Intelligent Electronic Devices (IEDs, IEC 61850 Servers) on the network using the IEC 61850 protocol.

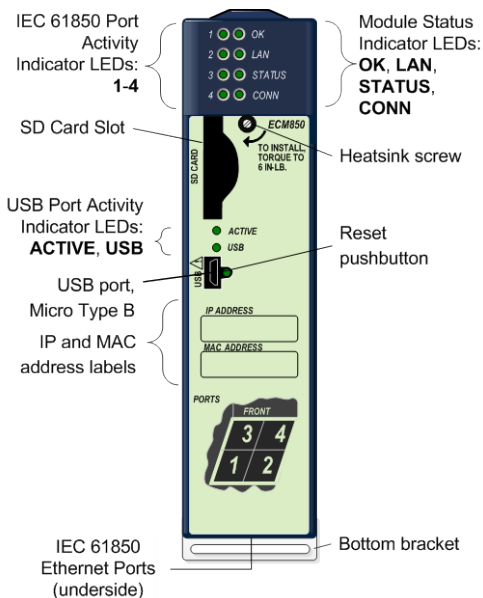

1.2. Ethernet Ports

The ECM850 connects to one IEC 61850 network by means of one or more of its four external Ethernet ports. Two 8-conductor RJ-45 shielded twisted pair 10/100/1000 Mbps copper interfaces and two Small Form-factor Pluggable (SFP) cages provide flexibility in media selection.

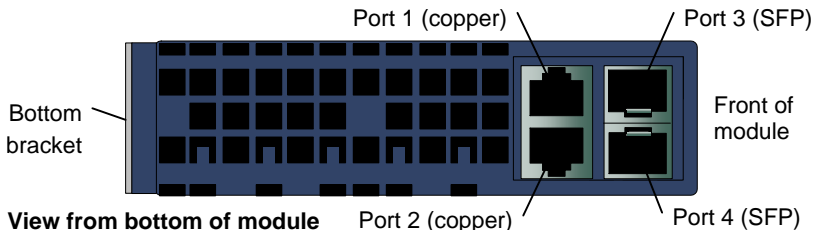

The module is assigned five Ethernet MAC addresses: one for each of the four external Ethernet ports and one for the internal switch.

SFP Modules

Each SFP cage on the bottom of an ECM850 is capable of accepting the SFP devices listed below. SFP devices can be removed and replaced during module operation.

SFP Type	Wavelength (nm)	Media Type	Core Size (μm)	Modal Bandwidth (MHz – Km)	Distance (m)
100BASE-FX ¹	1300	MMF	62.5	500	2 – 2,000 (Full-Duplex) 2 – 400 (Half-Duplex)
			50	400	
			50	500	
100BASE-LX10	1300	SMF	9	-	2 – 10,000
1000BASE-SX	850	MMF	62.5	160	2 – 220
				200	2 – 275
			50	400	2 – 500
				500	2 – 550
1000BASE-LX	1300	SMF	9	-	2 – 10,000
1000BASE-ZX	1550	SMF	9	-	2 – 70,000
10/100/1000 BASE-T ²	-	CAT5/ CAT5e/ CAT6	-	-	100 (max)

¹ GE Intelligent Platforms part number IC695SPF002

² GE Intelligent Platforms part number IC695SPC100

1.3. Micro USB Port



The ECM850 has a USB Micro-B socket for connection to a computer. It can be used to access the ECM850's Command Line Interface function following the installation of special drivers. This port is intended for advanced maintenance and is not required for normal use. See the User Manual referenced in Section 5 for details.

1.4. Restart Pushbutton



The Restart pushbutton can be used to manually restart the module without cycling power. The restart operation begins when the pushbutton is released.

1.5. Light-Emitting Diode Indicators (LEDs)





OK —indicates whether the module is able to perform normal operations.

	Green, ON steady	OK
	Green, blink pattern	Fatal error. Flashes once between error codes blinked on the STATUS LED.
	OFF	Not OK



LAN—indicates access to and activity on the Ethernet local area network (LAN). The LAN LED indicates network packets are being processed by the network interface (not just passing through the embedded switch).

	Blinking ON	The module's network interface is active
	Blink pattern	Fatal error. Flashes once between error codes blinked on the STATUS LED
	OFF	No network activity



STATUS—indicates the condition of the ECM850 during normal operation. It is reset when the local log is cleared. For more information see the Command Line Interface *clear log* command.

	Green, ON	No new local log table entries
	OFF	New local log table entry
	Green, blink pattern	Fatal error. Error codes are blinked on this LED. See Chapter 5 of the User Manual for details.
	Red, blinking	Invalid MAC address (all MAC addresses are validated; error indicates if any address is bad)



CONFIG—indicates whether the module has received its configuration from the RX3i CPU.

	Green, ON	Configured
	OFF	Not configured
	Green, blink pattern	Fatal error. Flashes once between error codes blinked on the STATUS LED









ACTIVE—indicates the status of IEC 61850 connections.

	Green, ON	All configured IEC 61850 IEDs have established IEC 61850 connections
	Amber, ON	At least one configured IEC 61850 IED has established a connection, but at least one configured IED is not connected
	OFF	No configured IEDs have established connections to the ECM850, or hardware configuration is cleared.

USB—indicates activity on the USB port.

	Green, Blinking	USB port activity
	OFF	No USB port activity

Port LEDs — The ECM850 has four Port Indicator LEDs, 1, 2, 3, and 4 that indicate link speed, link connection and link activity corresponding to the four possible external Ethernet ports.

	Blue, ON	Link connected, 1000 Mbps
	Blue, blinking	Port active, 1000 Mbps
	Green, ON	Link connected, 100 Mbps
	Green, blinking	Port active, 100 Mbps
	Purple, ON	Link connected, 10 Mbps
	Purple, blinking	Port active, 10 Mbps
	Green, blink pattern	Fatal error. Flashes once between error codes blinked on the STATUS LED
	OFF	The associated Ethernet port is not connected to an active link
	Red, ON	Port 3 and port 4 only. Incompatible SFP plugged into port.

2. Hardware Installation

2.1. Initial Checks

Upon receiving your RX3i equipment, carefully inspect all shipping containers for damage. If any part of the system is damaged, notify the carrier immediately. The damaged shipping container should be saved as evidence for inspection by the carrier.

As the consignee, it is your responsibility to register a claim with the carrier for damage incurred during shipment. GE Intelligent Platforms will fully cooperate with you, however, should such action be necessary.

After unpacking the RX3i equipment, record all serial numbers. Serial numbers are required if you should need to contact Customer Care during the warranty period. All shipping containers and all packing material should be saved should it be necessary to transport or ship any part of the system.

Verify that all components of the system have been received and that they agree with your order. If the system received does not agree with your order, contact Customer Care.

2.2. Installation Location

This product is intended for use with the RX3i system. Its components are considered open equipment (having live electrical parts that may be accessible to users) and must be installed in an ultimate enclosure that is manufactured to provide safety. As a minimum, the enclosure shall

provide a degree of protection against solid objects as small as 12mm (e.g. fingers). This equates to a NEMA/UL Type 1 enclosure or an IP20 rating (IEC60529) providing at least a pollution degree 2 environment. For details about installing RX3i rack systems, refer to GFK-2314.

If you need technical help, contact Technical Support. For phone numbers and email addresses, see the “Contact Information” page in the front of the user manual referenced in section 5.

2.3. Installation in Hazardous Areas

The following information is for products bearing the UL marking for Hazardous Areas or ATEX marking for explosive atmospheres:

CLASS 1 DIVISION 2 GROUPS ABCD

- This equipment is an open-type device and is meant to be installed in an enclosure suitable for the environment that is only accessible with the use of a tool.
- Suitable for use in Class I, Division 2, Groups A, B, C and D Hazardous Locations, or nonhazardous locations only.



Warning – EXPLOSION HAZARD - SUBSTITUTION OF COMPONENTS MAY IMPAIR SUITABILITY FOR CLASS I, DIVISION 2.



Warning – WHEN IN HAZARDOUS LOCATIONS, TURN OFF POWER BEFORE REPLACING OR WIRING MODULES; AND



Warning – DO NOT CONNECT OR DISCONNECT EQUIPMENT UNLESS POWER HAS BEEN SWITCHED OFF OR THE AREA IS KNOWN TO BE NONHAZARDOUS.



Warning – EXPLOSION HAZARD - USB PORT IS ONLY FOR USE IN NONHAZARDOUS LOCATIONS, DO NOT USE UNLESS AREA IS KNOWN TO BE NON-HAZARDOUS.

ATEX Zone 2

The ECM850 must be mounted in an enclosure certified in accordance with EN60079-15 for use in Zone 2, Group IIC and rated IP54. The enclosure shall only be able to be opened with the use of a tool.

ATEX Marking



II 3 G Ex nA IIC T5 X Ta: 0 - 60C

2.4. Module Installation

The ECM850 must be installed in the main (CPU) rack of an RX3i system, using a Universal Backplane such as IC695CHS007, CHS012 or CHS016. The ECM850 supports insertion/removal while power is applied to the system (hot swap). This module is compatible with RX3i CPU models CPU320,CPU315,CPE305,CPE310 and CRU320.

Removing the Backplane Knockout

The back of the ECM850 has an exposed heat sink and backplane connector. Before inserting the module into the backplane, remove the plastic knockout in the slot where the module will be placed (see figure).

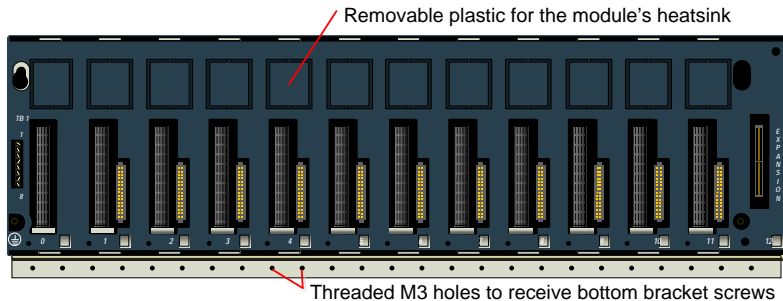

The installation slot must match the slot that is selected in the module's hardware configuration in the Proficy* Machine Edition application.

Module Insertion

- RX3i rack power may be off or on ("hot insertion").
- Holding the module firmly, align the module with the correct slot and connector.
- Swing the module down until the module's connector engages the backplane's backplane connector.
- Visually inspect the module to be sure it is properly seated.

- Turn the heat sink screw on the front of the module several turns into the threaded hole in the backplate using a flat-tip screwdriver, but do not tighten.
- Insert the two provided M3x5 machine screws through the module's bottom bracket into threaded holes in the bottom of the backplate and screw them several turns using a #1 Phillips screwdriver, but do not tighten.
- Tighten the heat sink screw to 6 in-lbs (0.7 N-m).
- Tighten the bottom bracket screws.

2.5. Ethernet Port Connections to IEC 61850 LAN

Each port on an ECM850 operates independently through an embedded Ethernet switch, so devices that operate at different speeds and/or duplex modes can be attached to different ports. Each port automatically detects the attached cable and functions properly with either straight-through or crossover cables.

Note: The ECM850 operates only in autonegotiate mode. All IEC 61850 devices and switches that are connected to the ECM850 should be configured to use autonegotiation.

IEC 61850 LAN Topologies

There are three basic topologies that can be used alone or in combination for connecting an ECM850 with up to 32 IEDs on an IEC 61850 network. Each of these methods is illustrated and described below.

Direct

The simplest scheme is the direct connection of IEDs to the ports of the ECM850. This limits the number of IEDs served by an ECM850 to four.

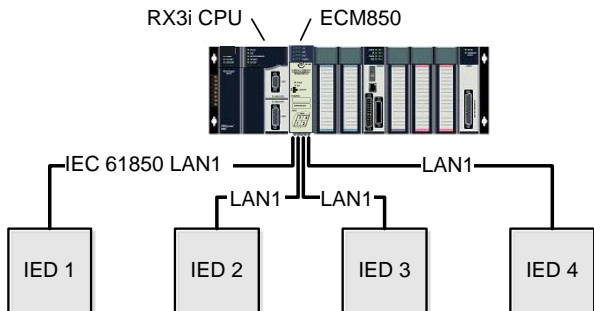

Linear

Some IEDs are provided with at least two Ethernet ports and an internal Ethernet switch, allowing them to be connected in a daisy-chain as shown below.

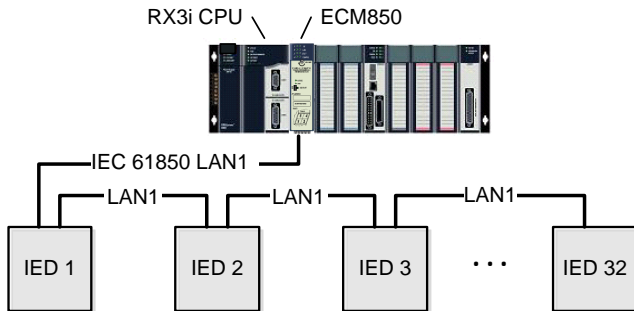

Star (Switched)

When more than a few IEDs must be networked, the preferred method of connecting the devices is by means of one or more network switches. The diagram below shows a single ECM850 port connected to one port of a switch, leaving the remainder of the switch's ports available for connection to IEDs. If more IEDs must be connected, more switches can be connected to the ECM850's other ports, or additional switches can be connected to the first.

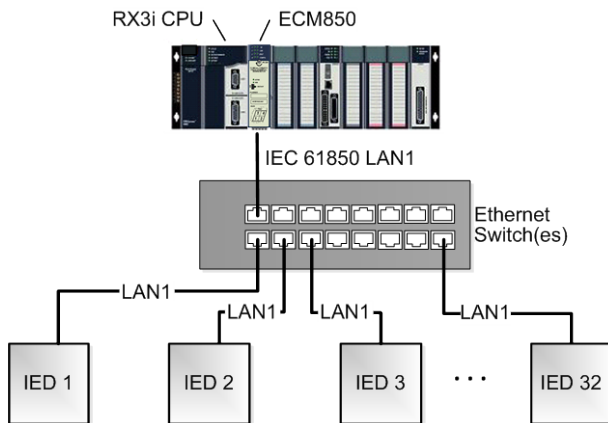

3. Configuration

You will need:

- PACSystems RX3i CPU Firmware 8.05 or later.
- Proficy Machine Edition configuration and programming software, version 8.0 SIM 7 or later.
- Serial or Ethernet cable for connecting the Proficy Machine Edition programmer computer to the RX3i CPU.
- IED Capability Description (ICD) or Configured IED Description (CID) files for the devices in your system, available from the device manufacturers.
- *PACSystems RX3i IEC 61850 Ethernet Communication Module User Manual*, GFK-2849, available from the GE Intelligent Platforms support website, <http://www.ge-ip.com/support>. You will need to refer to this manual to fully configure and commission the ECM850.

3.1. Confirm ECM850 Communication with the CPU

Start the Machine Edition application, then open or create the project to contain the ECM850. After configuring the rack, power supply, and CPU in the Project tab of the Navigator, go online with the target, right-click on the target and select **Online Commands** ►, **Show Status...**, **Details**, to display the **Device Information Details** window. This queries the CPU

and all modules present on all racks in the system, whether configured or not. If the ECM850 is displayed in the list similar to the following screenshot, it indicates that the module has powered up as expected, is communicating with the CPU over the rack backplane, and that it is ready for further configuration.

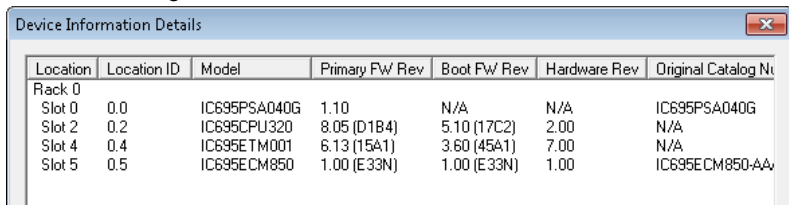

Location	Location ID	Model	Primary FW Rev	Boot FW Rev	Hardware Rev	Original Catalog No
Rack 0						
Slot 0	0.0	IC695PSA040G	1.10	N/A	N/A	IC695PSA040G
Slot 2	0.2	IC695CPU320	8.05 (D1B4)	5.10 (17C2)	2.00	N/A
Slot 4	0.4	IC695ETM001	6.13 (15A1)	3.60 (45A1)	7.00	N/A
Slot 5	0.5	IC695ECM850	1.00 (E33N)	1.00 (E33N)	1.00	IC695ECM850-AA

3.2. Next Steps

The full configuration of the ECM850 is beyond the scope of this Guide, but is covered in detail in the User Manual, GFK-2849, referenced in section 5. In brief, the steps are the following:

1. **Add ECM850 to RX3i Target Hardware Configuration:** select the slot in which the ECM850 is installed, right-click and select **Add Module**. From the Communications tab of the Module Catalog, select the IC695ECM850 module. Double-clicking the slot with the IC695ECM850 displays a Settings grid where you can enter (among others) the module's IEC 61850 network IP address, subnet mask, and Status Address.

2. **Add IEDs and select IEC 61850 Data Objects/Data Attributes (DO/DA):** Right-click the slot with the IC695ECM850 and select **Configure IEC61850 Client** to display the integrated **IEC61850 Configurator** to define and configure the IEDs with which the ECM850 will communicate. The IEC 61850 Configurator supports both online and offline configuration. Online, the user can connect to the IED and browse the device's data model to select objects of interest. Offline, the user can import an IED Capability Description (ICD) or Configured IED Description (CID) file preconfigured by the IED vendor to browse and select the device's data objects. Machine Edition automatically generates "PLC Protocol Variables" (PPVs) from these objects for use in the ladder application.
3. **Create the RX3i application:** Finally, the variables created in the previous step are used to develop an RX3i application program. This program, along with the hardware configuration and network configuration is then downloaded to the RX3i controller for validation and deployment.

4. Status and Diagnostic Data

4.1. Module Status Data (32 bits)

Bit	Name	Description
1 (LSB)	Module OK	1 indicates the module is functioning properly. 0 indicates the module is powering up or has failed
2	Port1 Link Up	1 indicates the port is connected to another device and is operating correctly. 0 indicates the port is not connected to another device, the port has an error preventing communications, or the SFP cage is empty or has an incompatible SFP device.
3	Port2 Link Up	
4	Port3 Link Up	
5	Port4 Link Up	
6-8	Reserved	Always 0
9	All Devices Connected	1 indicates all configured devices are connected and communicating over IEC61850 protocol. 0 indicates no devices are configured or one or more configured devices have not established a IEC 61850 connection.
10	Outputs Disabled	1 indicates Protocol Outputs are disabled and shall not be sent to IED device over wire 0 indicates Protocol Outputs are enabled and shall be sent to IED device over the wire.
11-32	Reserved	Always 0

4.2. Problems during Powerup and Reset

Certain conditions can prevent the module from becoming operational.

Problem	Indication	Action
Hardware failure	All Indicator LEDs off. Module unresponsive.	Return the module to GE Intelligent Platforms.
Invalid bootstrap image		
Invalid boot image	<ul style="list-style-type: none">• No Indicator LEDs turn on and the module is unresponsive, or• The STATUS LED is solid green and is the only LED on.	
Fatal powerup initialization failure	Fatal Error LED blink code	Note the blink code and contact Customer Service.
Non-fatal initialization failure	Module powers up normally, but an entry is added to the Local Log table and the RX3i CPU fault table.	Note the fault and contact Customer Service.
Module does not contain hardware identity info	Fatal Error LED blink code	Note the blink code and contact Customer Service.

5. Additional Information

5.1. PACSystems RX3i User Manuals

PACSystems RX3i and RX7i CPU Reference Manual, GFK-2222

PACSystems RX3i System Manual, GFK-2314

PACSystems RX3i IEC 61850 Ethernet Communication Module User Manual, GFK-2849

PACSystems RX3i IEC 61850 Ethernet Communication Module Important Product Information, GFK-2850

User manuals, product updates and other information sources are available on the Support website, <http://www.ge-ip.com/support>, under *Controllers and IO, RX3i Controllers*.

5.2. Information about IEC 61850

For detailed information about the IEC 61850 standard, contact the International Electrotechnical Commission Technical Committee 57, Power Systems Management and Associated Information Exchange: www://tc57.iec.ch/.

GE Intelligent Platforms

Contact Information

Americas: 1-800-433-2682 or 1-434-978-5100

Global regional phone numbers are available on our web site

www.ge-ip.com



©2014 GE Intelligent Platforms, Inc. All Rights Reserved

*Trademark of GE Intelligent Platforms, Inc.

All other brands or names are property of their respective holders

GFK-2851